

# BEIJERS

115 ÅR AV ERFARENHET OCH NYTÄNKANDE  
*SLIPMASKINER STATIONÄRA (ACETI)*



PRODUKTKATALOG 2020 | *SLIPTEKNIK*

# BEIJERS

EN DEL AV **BEJERTECH**

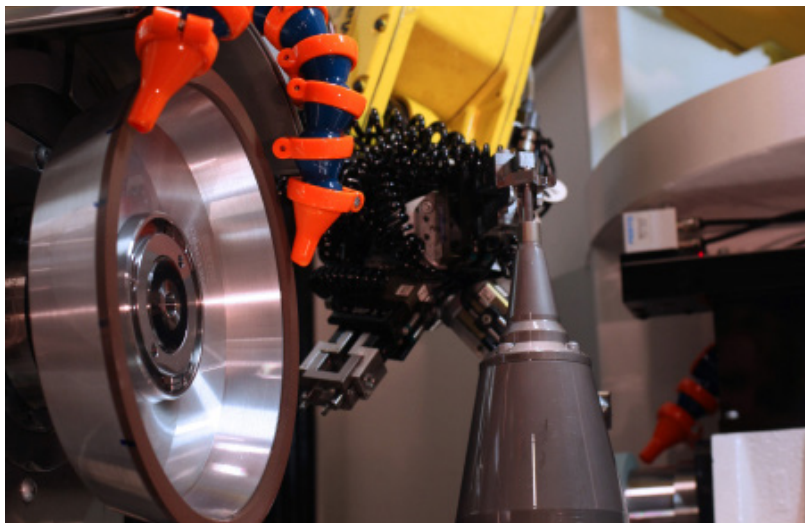

## AFFÄRSSEGMENT SLIPMATERIAL

Beijer Industri, affärssegment slipmaterial, kan tack vare sitt breda kontaktnät av leverantörer erbjuda ett komplett produktsortiment av slip- och polermaterial för metallindustrin. Vi representerar ledande leverantörer inom området och lagerför våra produkter i Malmö. Lång erfarenhet och bred kompetens gör oss till specialister inom dessa segment där vi idag, tillsammans med våra kunder och leverantörer, arbetar för att hitta effektiva kundanpassade lösningar.

## VI ERBJUDER

Vårt utbud är omfattande och innefattar bland annat:

### Flexibela slipmaterial

Slipduk som band, hylsor, koner, rullar, rondell och ark. Lamellprodukter som rondeller, stift och skivor. Fiber-rondeller, kvickrondeller och kardborrerondeller samt kontakt- och självexpanderade skivor.

### Hårda slipmaterial

Precisionslipskivor, verktygsslipskivor, grovslipskivor, skärpverktyg, kap- och navrondeller, slipstift, slipskålar, sliptoppar och brynen.

### Diamant och CBN

Slipskivor, dresskivor, stift, filar, pasta och brynen.

### Produkter för gradning

Borstar, hårdmetallfilor, gradningsskivor, -stift och keramiska knivar.

### Polerprodukter

Polernylon som skivor, stift, ark, band och valsar. Sisalskivor, fiberborstar, bomull och polyesteresskivor samt vax.

### Maskiner - Övrigt

Bandslipmaskiner, handhållna slipmaskiner, polermaskiner och sågblad.

## KONTAKTA OSS

Beijer Industri AB

Jägershillgatan 16

213 75 Malmö

Tel: +46 40 35 83 26

E-post: [slip@beijerind.se](mailto:slip@beijerind.se)

[www.beijerind.se](http://www.beijerind.se)



# BEJERTECH

INDUSTRIAL PRODUCTS

BEIJERS

KARLEBO

PTMU

TEBECO

# HUR KAN VI HJÄLPA DIG?

## *ETT KOMPLETT SORTIMENT*

Genom vårt globala kontaktnät av leverantörer kan vi erbjuda ett komplett produktsortiment av slip- och polermaterial för metallindustrin. Saknar du någon produkt? Kontakta oss så hjälper vi dig.

Tel: [+46 40 35 83 26](tel:+4640358326) E-post: [slip@beijerind.se](mailto:slip@beijerind.se)

## *KUNDANPASSADE LÖSNINGAR*

Utöver de produkter som ingår i vårt standardsortiment tillhandahåller vi kundanpassade lösningar. Med lång erfarenhet och bred kompetens strävar vi efter att finna den bästa lösningen för dig som kund. Tillsammans arbetar vi fram en effektiv lösning. Slå oss en signal eller skicka ett mail så berättar vi mer.

Tel: [+46 40 35 83 26](tel:+4640358326) E-post: [slip@beijerind.se](mailto:slip@beijerind.se)

## *OFFERTFÖRFRÅGAN*

Har du önskemål om en offert eller frågor om pris och leveranstid är du välkommen att kontakta oss.

Tel: [+46 40 35 83 26](tel:+4640358326) E-post: [slip@beijerind.se](mailto:slip@beijerind.se)

## *SÅ HÄR BESTÄLLER DU*

Du beställer önskade produkter snabbt och enkelt via vår kundservice eller e-post.

Tel: [+46 40 35 83 00](tel:+4640358300) E-post: [order@beijerind.se](mailto:order@beijerind.se)

# VÅRA VARUMÄRKEN







# BEIJERS

## SLIPMASKINER STATIONÄRA

### BANDSLIPMASKIN 76

En bandslipmaskin för slipning av plana detaljer. Maskinen är anpassad för både torr- och våtslipning och kan utrustas med ett antal tillval för att passa just era behov. Som tillval kan maskinen, utöver två stycken specialdesignade rullbord för att underlätta slipning av längre detaljer, utrustas med:

- Totalt fyra stycken arbetsstationer för önskad finish (3 slibandsstationer + 1 borststation)
- Torkzon för användning i samband med våtslipning
- Inverterer för elektronisk justering av slipbandets hastighet (0-3000 Rpm)
- Tank för automatisk filtrering av kylmedel
- Utsug med cyklonsystem



Volt 400 kW 4,6					
hp Rpm m/s	E F G G1	dB	kg	A B C D m/min	Sp La max Lu min
6 1500 8	1250 1200 2100 900	85	625	1900 300 830 300 1+10	0+205 300 140

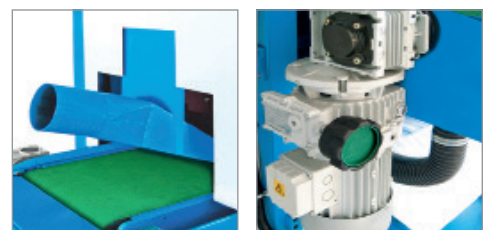



# BEIJERS

SLIPMASKINER STATIONÄRA

## BANDSLIPMASKIN 76

En bandslipmaskin med en slipbandsstation. Utrustad med slipband 300X1900.



## BANDSLIPMASKIN 76 1N + 2S

En bandslipmaskin med en slipbandsstation + en borststation. Utrustad med slipband 300X1900 samt borste Ø200X300.



## BANDSLIPMASKIN 76 2N

En bandslipmaskin med två stycken slipbandsstationer. Utrustad med slipband 300X1900.





# BEIJERS

SLIPMASKINER STATIONÄRA

## BANDSLIPMASKIN 76 - TILLVAL

Specialdesignade rullbord för att underlätta slipning av längre detaljer.



## BANDSLIPMASKIN 76 - TILLVAL

Borststation för borste Ø200X300.

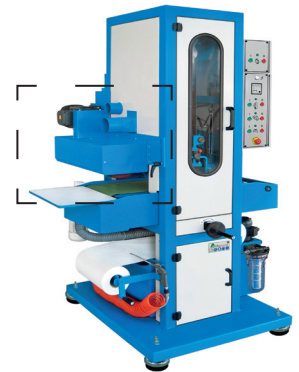

## BANDSLIPMASKIN 76 - TILLVAL

Torkzon för användning i samband med våtslipning.





# BEIJERS

SLIPMASKINER STATIONÄRA

---

## BANDSLIPMASKIN 76 - TILLVAL

Utsug med cyklonsystem



---

## BANDSLIPMASKIN 76 - TILLVAL

Tank för automatisk filtrering av kylmedel







# BEIJERS

## SLIPMASKINER STATIONÄRA

### BANDSLIPMASKIN 76 2N + 2S

En bandslipmaskin med två stycken slipbandsstationer + en borststation. Utrustad med slipband 300X1900 samt borste Ø200X300.



### BANDSLIPMASKIN 97

En bandslipmaskin med två fasta hastighetslägen för slipning av plana detaljer. Maskinen är anpassad för torrslipning och kan utrustas med ett antal tillval för att passa just era behov. Som tillval kan maskinen bland annat utrustas med:

- Ett specialdesignat rullbord för att underlätta slipning av längre detaljer
- Totalt två stycken arbetsstationer för önskad finish (2 slibbandsstationer)
- Inverterer för elektronisk justering av slipbandets hastighet (0-3000 Rpm)
- Utsug med cyklonsystem



Volt 400 kW 5			G1		G		dB		kg		A B		C D		m/min		Sp		La max		Lu min	
hp	Rpm	m/s	E	F	G	G1																
6,5	1400 2800	6 12	1250	870	1850	850	80	570	1750	220	1000	220	1+10	0+125	220	120						





# BEIJERS

SLIPMASKINER STATIONÄRA

## BANDSLIPMASKIN 97 2N

En bandslipmaskin med två stycken slipbandsstationer. Utrustad med slipband 220X1750



## BANDSLIPMASKIN 97 - TILLVAL

Specialdesignat rullbord för att underlätta slipning av längre detaljer.



## BANDSLIPMASKIN 97 - TILLVAL

Utsug med cyklonsystem





# BEIJERS

## SLIPMASKINER STATIONÄRA

### PLANSLIPMASKIN 143

En bandslipmaskin med två fasta hastighetslägen för slipning av plana detaljer som kan utrustas med inverter för för elektronisk justering av slipbandets hastighet (0-3000 Rpm).



Volt 400 kW 1,5																		
hp	Rpm	m/s	E	F	G	G1	dB	kg	A	B	Sp	La	Lu	kg max	INCLUDED	TAR.143	INVERTER	ASP.01
2	1400 2800	11 22	2000	1200	1700	490+1050	70	230	4000	120	1+560	550	1500	50	Nr.1	Nr.1	Rpm 0+3000	kW 1,5

### PLANSLIPMASKIN 144

En bandslipmaskin med två fasta hastighetslägen för slipning av plana detaljer. Som tillval kan maskinen utrustas med inverter för för elektronisk justering av slipbandets hastighet (0-3000 Rpm).

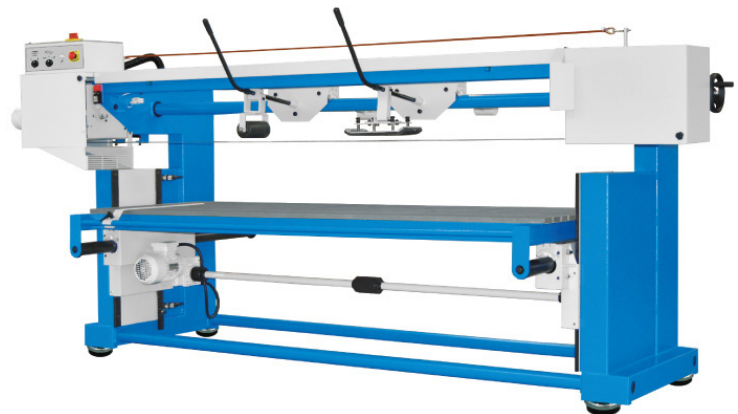

Volt 400 kW 5,2																	
hp	Rpm	m/s	E	F	G	G1	dB	kg	A	B	Sp	La	Lu	kg max	INCLUDED	INVERTER	ASP.01
7	700 1400	11 22	3700	2150	1600	600+1020	75	630	7000	150	1+420	800	2400	150	Nr.1 Nr.1 Nr.1	Rpm 0+1500	kW 3





# BEIJERS

## SLIPMASKINER STATIONÄRA

### RÖRSLIPMASKIN 150 2N/3N/4N

Rörslipmaskin med upp till fyra stycken arbetsstationer för önskad finish.







- 2N - Två stycken slipbandsstationer
- 3N - Tre stycken slipbandsstationer
- 4N - Fyra stycken slipbandsstationer

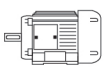
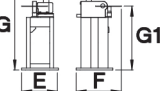

### RÖRSLIPMASKIN 78

Liten och smidg rörslipmaskin för mindre dimensioner av rör.

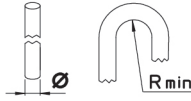

 <b>Volt 400 kW 0,75</b>								
hp	Rpm	m/s	E	F	G	G1	dB	kg
1	1500	7	540	665	1223	940	85	90
 <b>A</b> Nr. 2						<b>OPTIONAL</b> <b>IA-1</b>		
A	B	Ø mm		R min		kW		
280	11	Min 4 ÷ 20 Max		40		0,55		









# BEIJERS

## SLIPMASKINER STATIONÄRA

### CENTERLESS SLIPMASKIN 65

En bandslipmaskin med två fasta hastighetslägen för centerlesslipning av rör. Maskinen är anpassad för våtslipning och kan utrustas med ett antal tillval för att passa just era behov. Som tillval kan maskinen, bland annat utrustas med:

- Tre stycken arbetsstationer för önskad finish
- Tank för automatisk filtrering av kylmedel

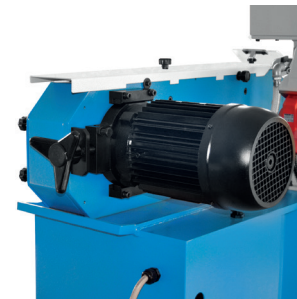
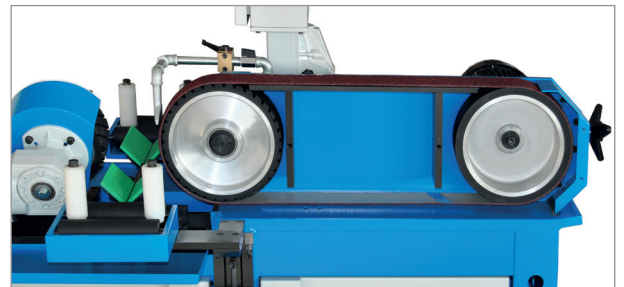

Volt 400 kW 5,2			E F G G1		kg		A B C D				Ø mm			
hp	Rpm	m/s	E	F	G	G1	dB	kg	A	B	C	D	Ø mm	Ø mm
7	1400 2800	18 36	1650	1000	1650	1010	75	385	2000	75	470	100	Ø250x75	Min 10 + 115 Max



# BEIJERS

## SLIPMASKINER STATIONÄRA

### CENTERLESS SLIPMASKIN 65 - TILLVAL



Tank för automatisk filtrering av kylmedel

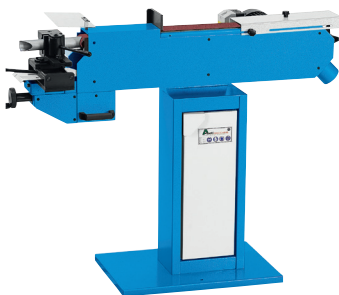

### RÖRSLIPMASKIN 60

En bandslipmaskin för radieslipning av rör.

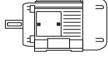
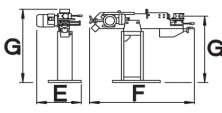

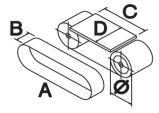
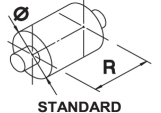
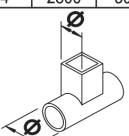
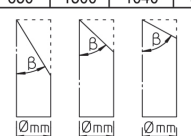
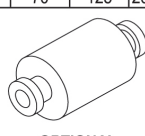
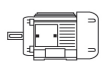
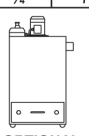
 <b>Volt 400 kW 3</b>													 <b>STANDARD</b>		
<b>hp</b>	<b>Rpm</b>	<b>m/s</b>	<b>E</b>	<b>F</b>	<b>G</b>	<b>G1</b>	<b>dB</b>	<b>kg</b>	<b>A</b>	<b>B</b>	<b>C</b>	<b>D</b>	<b>Ø</b>	<b>Ø"</b>	<b>R</b>
4	2800	30	650	1500	1040	960	70	125	2000	75	400	75	200	Ø1" ¼	75
						 <b>OPTIONAL</b>		 <b>OPTIONAL</b>			 <b>OPTIONAL</b>				
<b>Ø mm</b>			<b>Max Ø mm x β°</b>			<b>Ø</b>		<b>kW</b>			<b>Rpm</b>		<b>m/s</b>		<b>ASP.01</b>
Min 20 ÷ 70 Max			37x30° 52x45° 64x60°			20 -½"-¾"-1"-1"½"-2"- 70		3			1400 2800		15 30		kW 1,5



# BEIJERS

## SLIPMASKINER STATIONÄRA

### RÖRSLIPMASKIN 56

En bandslipmaskin med två fasta hastighetslägen för radieslipning av rör.



Volt 400 kW 5,2					STANDARD										
hp	Rpm	m/s	E	F	G	G1	dB	kg	A	B	C	D	Ø	Ø"	R
7	1400	15	800	1600	1250	1000	75	280	2000	150	400	160	200	Ø¼" - Ø1" ¼ - 3"	160
			Ø mm			Max Ø mm x β°			OPTIONAL Ø mm			OPTIONAL ASP.01			
			Min 20 + 145 Max			70x30° 102x45° 125x60°			20 + 145			kW 1,5			

### RÖRSLIPMASKIN 142

En bandslipmaskin för radieslipning av rör.

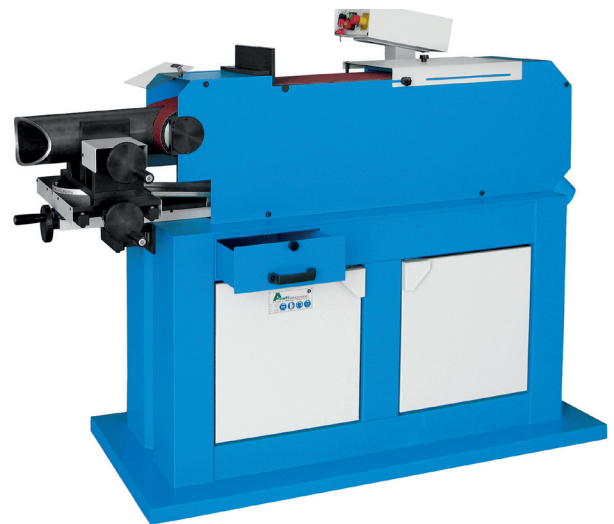

Volt 400 kW 6,5						
hp	Rpm	m/s	E	F	G	G1
9	1400	18	930	1900	1360	1010

						OPTIONALS							
dB	kg	A	B	C	D	Ø	Ø"	R	Ø mm	Max Ø mm x β°	Ø mm	Ø mm	ASP.01
75	430	2500	250	460	300	250	Ø 5"	250	Min 30 + 245 Max	121x30° 170x45° 210x60°	30 + 100	101 + 245	kW 1,5





# BEIJERS

## SLIPMASKINER STATIONÄRA

### RÖRSLIPMASKIN 130

En bandslipmaskin med justerbar bandposition (horisontellt eller vertikalt läge) och två fasta hastighetslägen för radieslipning av rör.



OPTIONAL Ø mm	OPTIONAL ASP.01
20 ÷ 145	kW 1,5







<b>Volt 400 kW 5,2</b>					STANDARD		
hp Rpm m/s	E F G G1	dB	kg	A B C D Ø	Ø " R	Ø mm	Max Ø mm x β°
7 1400 15 2800 30	950 1650 1250 1000	75	310	2000 150 400 160 200	Ø¾" - Ø1" ¼ - Ø3"	160 Min 20 ÷ 145 Max	70x30° 102x45° 125x60°

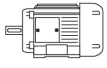

## BORSTGRADNINGSMASKIN 92

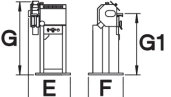
En borstgradningsmaskin utrustad med en arbetsstation och två fasta hastighetslägen för gradning av rör.

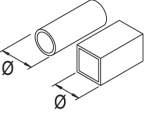





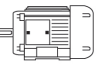

								
Volt 400 kW 4,4								
hp	Rpm	m/s	dB	E	F	G	G1	kg
6	1400 2800	18 36	75	670	540	1150	960	155
						OPTIONAL		
<b>Arm A</b>		<b>Arm A</b>		<b>IA-1</b>				
Max Ø60		Ø250x60xØ100		kW 0,55				

## BORSTGRADNINGSMASKIN 81

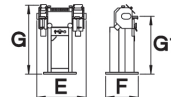
En borstgradningsmaskin utrustad med två stycken arbetsstationer och två fasta hastighetslägen för gradning av rör.

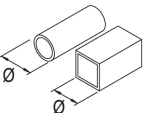

								
Volt 400 kW 4,4								
hp	Rpm	m/s	dB	E	F	G	G1	kg
6	1400 2800	18 36	75	850	540	1150	960	180
						OPTIONAL		
<b>Arm A</b>	<b>Arm B</b>	<b>Arm A</b>	<b>Arm B</b>	<b>IA-2</b>				
Max Ø60	Max Ø120	Ø250x60xØ100		Ø250x120xØ100		kW 0,55		





# BEIJERS

## SLIPMASKINER STATIONÄRA

### KANTAVGRADNINGSMASKIN 37

En kantavgradningsmaskin, med automatisk matning som tillval, för kantgradning av ståldetaljer.

 Nr.2 Volt 400 kW 0,75							 dB	 kg	 Nr. 2	 Sp
hp	Rpm	m/s	E	F	G	G1	dB	kg	Ø mm	Sp
1	1400	18	700	1000	1200	990	72	140	Ø250x50xØ100	0÷4
		 OPTIONAL: AUTOMATIC ADVANCING -AV.37-				 Kg max		 OPTIONAL		
C	D	kW	Rpm	m/min	Sp. max	kg max	IA-1			
120	1000	0,20	1400	1÷5	4	35	kW 0,55			



### KANTFASNINGSMASKIN 93

En kantfasningsmaskin med justerbar vinkelinställning och behändigt rullbord som tillval för ökad flexibilitet.



 Volt 400						 dB	 kg				 Sp		 kg 65
Nm	m/min	E	F	G	G1	dB	kg	Sm	Sp	J° VARIABLE	Ømin	INCLUDED	OPTIONAL
580	3	615	350	690	360	70	150	0÷18x30°	5÷60	22,5°-30°-37,5°-45°-52,5°	110	FR1	CAR.93
												Nr.1	H=460+800



# BEIJERS

## SLIPMASKINER STATIONÄRA

### KANTFASNINGSMASKIN 141

En kraftfull kantfasningsmaskin med justerbar vinkelinställning och behändigt rullbord för ökad flexibilitet.



Volt 400			kg			INCLUDED	INCLUDED						
Nm	m/min	E	F	G	G1	dB	kg	Sm	Sp	J° VARIABLE	Ømin	INCLUDED	INCLUDED
2400	2,3	970	850	1000	570	70	600	0÷30x30°	8÷60	22,5°-30°-37,5°-45°-52,5°	180	Nr.1	FR3 CAR.141
													H=420÷800

### KANTFASNINGSMASKIN 43

En liten och smidig kantfasningsmaskin för fasning av mindre detaljer.



Volt 400 kW 1,1			kg					
hp	Rpm	m/s	dB	E	F	G	G1	kg
1,5	2800	24	70	370	500	450	210	25
Ø mm	P	R	T	Sm	J°			
Ø165xØ22	500	0	120	0÷3	45°			









# BEIJERS

## SLIPMASKINER STATIONÄRA

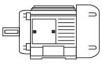
### BÄNKSLIPMASKIN 86

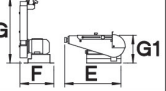
En liten och smidig bänkslipmaskin för allmän slipning. Som tillval kan maskinen utrustas med inverterer för elektronisk justering av slipbandets hastighet (0-3000 Rpm).

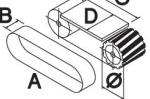





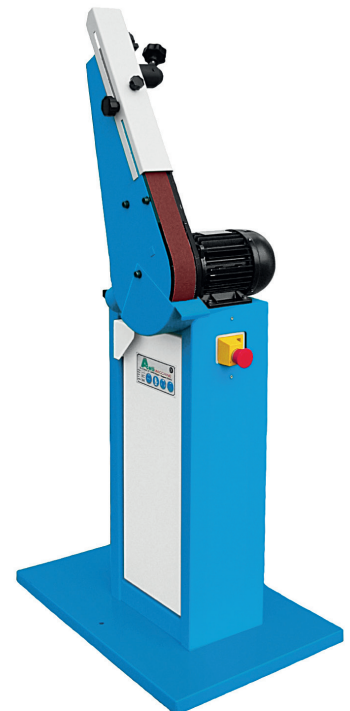

												
Volt 400 kW 1,1												
hp	Rpm	m/s	dB	F	E	G	G1	kg				
1,5	2800	30	68	370	580	690	290	30				
				OPTIONALS								
												
				Volt 230/1F INV.MF    BAS.01 Rpm 0=3000    ASP.04								
A	B	C	D	Ø mm	INV.MF		BAS.01					
1250	50	300	60	Ø200x50xØ20	Rpm 0=3000		ASP.04					

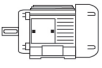
### PELARSLIPMASKIN 87

En pelarslipmaskin för allmän slipning. Som tillval kan maskinen utrustas med inverterer för elektronisk justering av slipbandets hastighet (0-3000 Rpm).

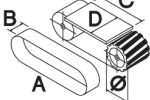

												
Volt 400 kW 1,1												
hp	Rpm	m/s	dB	F	E	G	G1	kg				
1,5	2800	30	68	450	750	1330	970	55				
				OPTIONALS								
												
				Volt 230/1F INV.MF    IA-1 Rpm 0=3000    kW 0,55								
A	B	C	D	Ø mm	INV.MF		IA-1					
1250	50	300	60	Ø200x50xØ20	Rpm 0=3000		kW 0,55					



# BEIJERS

## SLIPMASKINER STATIONÄRA

### BÄNKSLIPMASKIN 82

En liten och smidig bänkslipmaskin för allmän slipning och polering. Som tillval kan maskinen utrustas med inverterer för elektronisk justering av slipbandets och polerskivans hastighet (0-3000 Rpm).

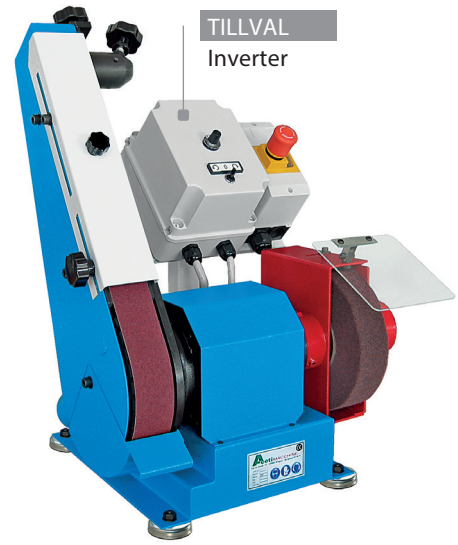

Volt 400 kW 1,1								
hp	Rpm	m/s	dB	F	E	G	G1	kg
1,5	2800	30	72	490	580	690	290	39
				OPTIONALS				
		NOT INCLUDED		Volt 230/1F				
A	B	C	D	Ø mm	Ø mm	INV.MF	BAS.01	
1250	50	300	60	Ø200x50xØ20	Ø200x50xØ20	Rpm 0-3000	ASP.04	

### BÄNKSLIPMASKIN 136

En liten och smidig bänkslipmaskin för allmän slipning. Som tillval kan maskinen utrustas med inverterer för elektronisk justering av slipbandets och slipskivans hastighet (0-3000 Rpm).



Volt 400 kW 1,1								
hp	Rpm	m/s	dB	F	E	G	G1	kg
1,5	2800	30	72	490	580	690	290	39
				OPTIONALS				
		NOT INCLUDED		Volt 230/1F				
A	B	C	D	Ø mm	Ø mm	INV.MF	BAS.01	
1250	50	300	60	Ø200x50xØ20	Ø200x25xØ20	Rpm 0-3000	ASP.04	





# BEIJERS

## SLIPMASKINER STATIONÄRA

### BÄNKSLIPMASKIN 22

En liten och smidig bänkslipmaskin med justerbar bandposition (horisontellt eller vertikalt läge) för allmän slipning.



Volt 400 kW 1,1								
hp	Rpm	m/s	dB	E	F	G	G1	kg
1,5	2800	15	70	550	450	600	150	28
		OPTIONALS						
A	B	C	D	Ø	BAS.01	ASP.04		
1000	100	290	100	100	kg 40	kg 45		

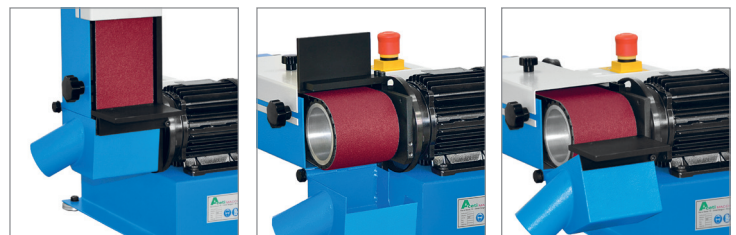

### PELARSLIPMASKIN 45

En pelarslipmaskin med justerbar bandposition (horisontellt eller vertikalt läge) för allmän slipning.



Volt 400 kW 1,1								
hp	Rpm	m/s	dB	E	F	G	G1	kg
1,5	2800	15	70	520	650	1300	790	60
		OPTIONALS						
A	B	C	D	Ø	IA-1			
1000	100	290	100	100	kW 0,55			

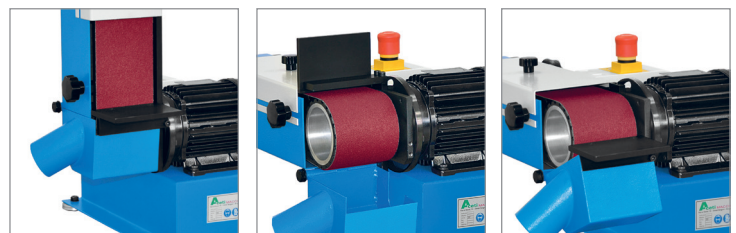





# BEIJERS

## SLIPMASKINER STATIONÄRA

### BÄNKSLIPMASKIN 89

En liten och smidig bänkslipmaskin med justerbar bandposition (horisontellt eller vertikalt läge) för allmän slipning och polering. Som tillval kan maskinen utrustas med inverterer för elektronisk justering av slipbandets och polerskivans hastighet (0-3000 Rpm).



Volt 400 kW 1,1									
hp	Rpm	m/s	dB	F	E	G	G1	kg	
1,5	2800	15	72	600	550	640	230	34	
						OPTIONALS			
			NOT INCLUDED						
A	B	C	D	Ø	Ø mm	INV.MF	BAS.01	ASP.04	
1000	100	290	100	100	Ø200x50xØ20	Rpm 0÷3000			

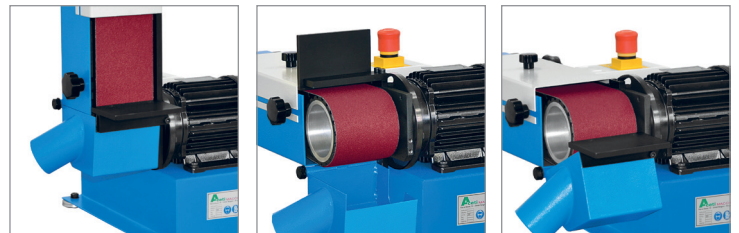

### BÄNKSLIPMASKIN 135

En liten och smidig bänkslipmaskin med justerbar bandposition (horisontellt eller vertikalt läge) för allmän slipning. Som tillval kan maskinen utrustas med inverterer för elektronisk justering av slipbandets och polerskivans hastighet (0-3000 Rpm).



Volt 400 kW 1,1									
hp	Rpm	m/s	dB	F	E	G	G1	kg	
1,5	2800	15	72	600	630	640	155	34	
						OPTIONALS			
			NOT INCLUDED						
A	B	C	D	Ø	Ø mm	INV.MF	BAS.01	ASP.04	
1000	100	290	100	100	Ø200x25xØ20	Rpm 0÷3000			

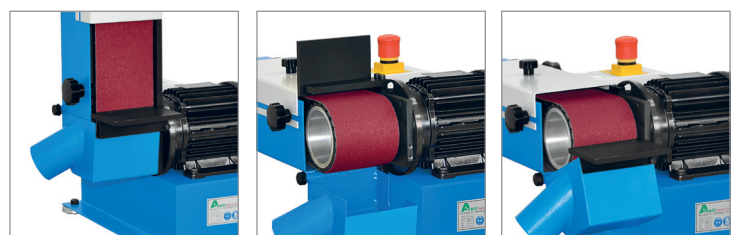



# BEIJERS



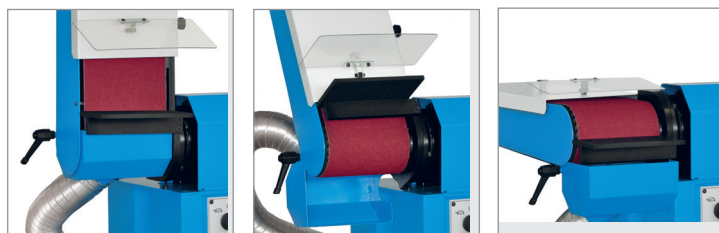
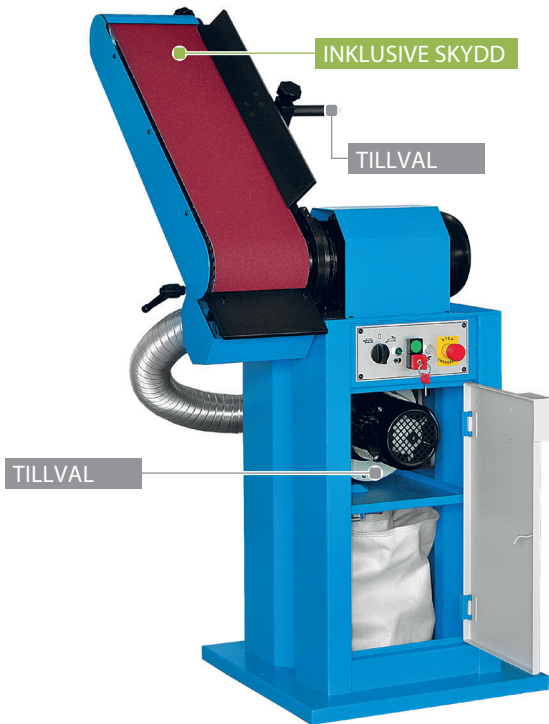

## SLIPMASKINER STATIONÄRA

### PELARSLIPMASKIN 16/07/63



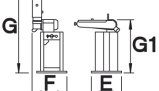

En pelarslipmaskin med två fasta hastighetslägen och justerbar bandposition (horisontellt eller vertikalt läge) för allmän slipning. Som tillval kan maskinen bland annat utrustas med utsug.

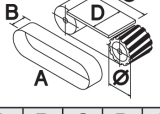
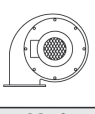
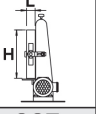



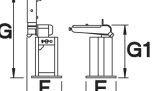

#### ART. 16

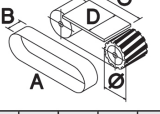
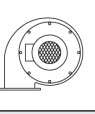
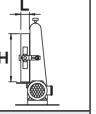
									
Volt 400 kW 1,8									
hp	Rpm	m/s	dB	E	F	G	G1	kg	
2,5	1400 2800	10 20	70	600	700	1600	980	100	
					OPTIONALS				
									
A	B	C	D	Ø	IA-1	SQT			
1500	120	470	120	135	kW 0,55	H=445	L=80		

#### ART. 07

									
Volt 400 kW 1,8									
hp	Rpm	m/s	dB	E	F	G	G1	kg	
2,5	1400 2800	10 20	70	600	700	1750	980	110	
					OPTIONALS				
									
A	B	C	D	Ø	IA-1	SQT			
1750	150	590	150	135	kW 0,55	H=570	L=80		

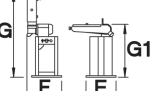
#### ART. 63

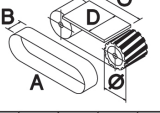
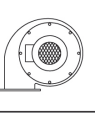
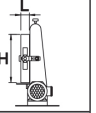
									
Volt 400 kW 3									
hp	Rpm	m/s	dB	E	F	G	G1	kg	
4	1400 2800	10 20	70	600	750	1750	980	115	
					OPTIONALS				
									
A	B	C	D	Ø	IA-1	SQT			
1750	200	590	200	135	kW 0,55	H=570	L=80		



# BEIJERS

## SLIPMASKINER STATIONÄRA

### PELARSLIPMASKIN 08

En pelarslipmaskin med två fasta hastighetslägen och justerbar bandposition (horisontellt eller vertikalt läge) för allmän slipning. Som tillval kan maskinen, bland annat, utrustas med utsug.

Volt 400 kW 1,8								
hp	Rpm	m/s	dB	E	F	G	G1	kg
2,5	1400 2800	10 20	70	600	650	1600	980	145
		OPTIONALS						
A	B	C	D	Ø	SQT		IA-2	
1500	120	470	120	135	H=445   L=80		kW 0,55	



### PELARSLIPMASKIN 06

En pelarslipmaskin med två fasta hastighetslägen och justerbar bandposition (horisontellt eller vertikalt läge) för allmän slipning. Som tillval kan maskinen, bland annat, utrustas med utsug.

Volt 400 kW 1,8								
hp	Rpm	m/s	dB	E	F	G	G1	kg
2,5	1400 2800	10 20	70	600	700	1600	980	115
		NOT INCLUDED		OPTIONAL				
A	B	C	D	Ø	Ø mm		IA-2	
1500	120	470	120	135	Ø200x25xØ20		kW 0,55	











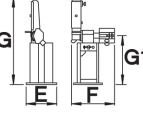

## PELARSLIPMASKIN 05

En pelarslipmaskin med två fasta hastighetslägen och justerbar bandposition (horisontellt eller vertikalt läge) för allmän slipning och polering. Som tillval kan maskinen, bland annat, utrustas med utsug.

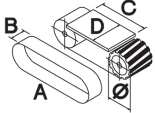

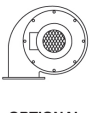



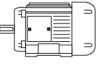

								
Volt 400 kW 1,8								
hp	Rpm	m/s	dB	E	F	G	G1	kg
2,5	1400 2800	10 20	70	600	900	1600	910	115
								
			NOT INCLUDED	OPTIONAL				
A	B	C	D	Ø	Ø mm	IA-2		
1500	120	470	120	135	Ø250xØ25	kW 0,55		

## PELARSLIPMASKIN 127

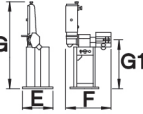
En pelarslipmaskin med två fasta hastighetslägen och justerbar bandposition (horisontellt eller vertikalt läge) för allmän slipning och polering. Som tillval kan maskinen, bland annat, utrustas med utsug.

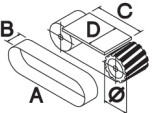

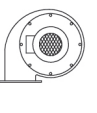
								
Volt 400 kW 4,4								
hp	Rpm	m/s	dB	E	F	G	G1	kg
6	1400 2800	10 20	70	600	920	1750	910	170
								
			NOT INCLUDED	OPTIONAL				
A	B	C	D	Ø	Ø mm	IA-2		
1750	200	590	200	135	Ø300xØ35	kW 0,55		









# BEIJERS

## SLIPMASKINER STATIONÄRA

### BANDSLIPMASKIN 67

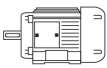
En bandslipmaskin för allmän slipning. Som tillval kan maskinen utrustas med utsug.

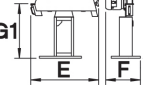

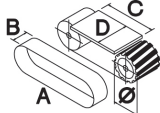
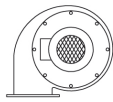
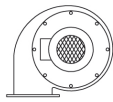



								
Volt 400 kW 3								
hp	Rpm	m/s	dB	E	F	G	G1	kg
4	2800	30	73	1100	550	1000	840	90
								
		OPTIONAL		IA-1				
A	B	C	D	Ø	kW 0,55			
2000	75	605	100	200				

### BANDSLIPMASKIN 33

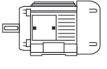
En bandslipmaskin med två fasta hastighetslägen för allmän slipning. Som tillval kan maskinen utrustas med utsug.

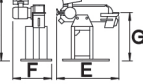

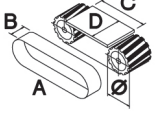
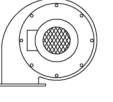
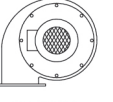
								
Volt 400 kW 3,7								
hp	Rpm	m/s	dB	E	F	G	G1	kg
5	1400 2800	18 36	75	1100	700	1150	830	150
								
		OPTIONAL		IA-2				
A	B	C	D	Ø	kW 0,55			
2000	75	470	100	250				



# BEIJERS

## SLIPMASKINER STATIONÄRA

### BANDSLIPMASKIN 38

En bandslipmaskin med två fasta hastighetslägen för allmän slipning. Som tillval kan maskinen utrustas med utsug. (Inklusive skydd)

Volt 400 kW 3,7								
hp	Rpm	m/s	dB	E	F	G	G1	kg
5	1400 2800	18 36	75	1100	700	1150	830	180
OPTIONAL IA-2								
A	B	C	D	Ø	kW 0,55			
2000	150	470	180	250				

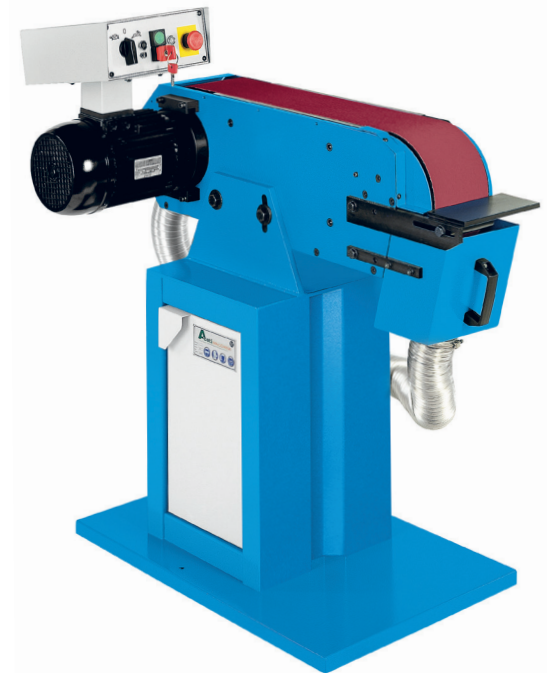

### BANDSLIPMASKIN 90

En bandslipmaskin med två fasta hastighetslägen för allmän slipning. Som tillval kan maskinen utrustas med utsug.

Volt 400 kW 4,5														
hp	Rpm	m/s	dB	E	F	G	G1	kg	A	B	C	D	Ø	OPTIONAL ASP.01
7	1400 2800	18 36	75	1420	700	1150	830	220	2500	200	720	230	250	kW 1,5





# BEIJERS

## SLIPMASKINER STATIONÄRA

### BANDSLIPMASKIN 73N

En vertikal bandslipmaskin med två fasta hastighetslägen och ställbart mothåll för slipning av plana och vinklade detaljer  
Som tillval kan maskinen utrustas med utsug.



 Volt 400 kW 3						 kg										 OPTIONAL ASP.01		
hp	Rpm	m/s	E	F	G	G1	dB	kg	A	B	Ø	D	M	N	P	T	J°	ASP.01
4	1400 2800	10 20	1050	550	1200	910	70	225	1750	200	135	200	565	300	565	300	-45°/+45°	kW 1,5

### RONDELLSLIPMASKIN 24

En vertikal rondellslipmaskin med två fasta hastighetslägen och ställbart mothåll. Som tillval kan maskinen utrustas med utsug.



 Volt 400 kW 1,8						 kg		
hp	Rpm	m/s	dB	E	F	G	G1	kg
2,5	1400 2800	30 60	70	600	800	1300	920	105
			 OPTIONAL IA-1					
Ø	M	N	J°	kW 0,55				
400	450	230	0°/+90°					



# BEIJERS

## SLIPMASKINER STATIONÄRA

### RONDELLSLIPMASKIN 62

En vertikal rondellslipmaskin med två fasta hastighetslägen och ställbart mothåll. Som tillval kan maskinen utrustas med utsug.

Volt 400 kW 3								
hp	Rpm	m/s	dB	E	F	G	G1	kg
4	950	30	68	700	800	1360	900	135
				OPTIONAL				
Ø	M	N	J°	IA-1				
600	650	230	0°+90°	kW 0,55				



### RONDELLSLIPMASKIN 52

En vertikal rondellslipmaskin med två fasta hastighetslägen och ställbart mothåll. Som tillval kan maskinen utrustas med utsug.

Volt 400 kW 4								
hp	Rpm	m/s	E	F	G	G1	dB	kg
5,5	950	40	1300	1000	1450	870	70	370
				OPTIONAL				
Ø	M	N	J°	ASP.01				
800	1000	300	-45°+45°	kW 1,5				







# BEIJERS

## SLIPMASKINER STATIONÄRA

### RONDELLSLIPMASKIN 98

En horisontell rondellslipmaskin. för slipning av plana ytor. Som tillval kan maskinen utrustas med utsug.

Volt 400 kW 3												
hp	Rpm	m/s	dB	E	F	G	G1	kg				
4	950	30	68	850	650	970	880	130				
OPTIONAL ASP.03												
kW 0,75												
				Ø				C				
				600				80				



### PELARSLIPMASKIN 21

En pelarslipmaskin med två fasta hastighetslägen, justerbar bandposition (horisontellt eller vertikalt läge) och ställbart mothåll för rondellslip. Som tillval kan maskinen utrustas med utsug.

Volt 400 kW 1,8												
hp	Rpm	m/s	dB	E	F	G	G1	kg				
2,5	1400 2800	10 20	70	600	800	1600	980	145				
OPTIONAL IA-2												
kW 0,55												
A	B	C	D	Ø	Ø	M	N	J°				
1500	120	470	120	135	400	450	230	0°-90°				

TILLVAL  
Damsug

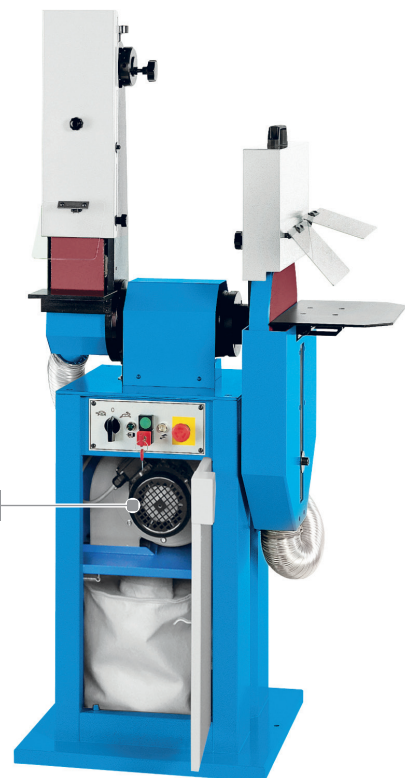



## PELARSLIPMASKIN 99

En pelarslipmaskin med två fasta hastighetslägen, justerbar bandposition (horisontellt eller vertikalt läge) och ställbart mothåll för rondellslip. Som tillval kan maskinen utrustas med utsug.



Volt 400 kW 4									
hp	Rpm	m/s	dB	E	F	G	G1	kg	
5,5	700 1400	5 10	75	600	880	1750	980	240	
						OPTIONAL			
A	B	C	D	Ø	Ø	M	N	J°	IA-2
1750	200	590	200	135	600	650	230	0°+90°	kW 0,55

## PELARSLIPMASKIN 30

En pelarslipmaskin med två fasta hastighetslägen, justerbar bandlängd för bättre livslängd och ökad flexibilitet samt ställbart mothåll för rondellslip. Som tillval kan maskinen utrustas med utsug.

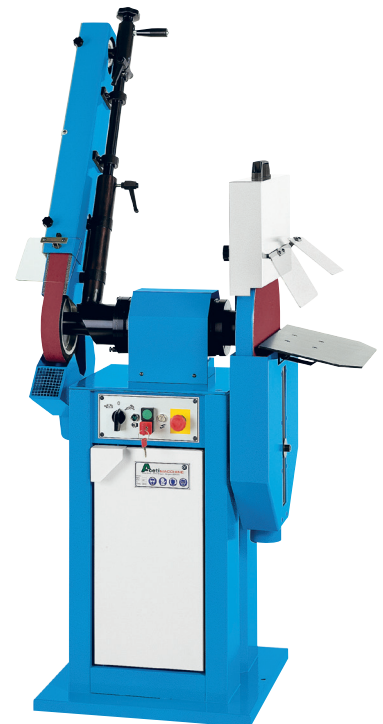

Volt 400 kW 1,8								
hp	Rpm	m/s	dB	E	F	G	G1	kg
2,5	1400 2800	15 30	70	600	900	1850	910	150
						OPTIONAL		
Ø mm		A		B		IA-2		
400		450		230		0°+90°		
						kW 0,55		

Ø200x50xØ20	2000+2500	50
OPTIONAL		
IA-2		
kW 0,55		



# BEIJERS

## SLIPMASKINER STATIONÄRA

### PELARSLIPMASKIN 26

En pelarslipmaskin med två fasta hastighetslägen för slipning och polering. Som tillval kan maskinen utrustas med utsug.



Volt 400 kW 1,8								
hp	Rpm	m/s	dB	E	F	G	G1	kg
2,5	1400 2800	18 36	70	600	1000	1300	910	120
$\emptyset$	M	N	J°	NOT INCLUDED		OPTIONAL		
400	450	230	0°-90°	Ø250xØ25		IA-2		kW 0,55

### PELARSLIPMASKIN 32

En pelarslipmaskin med två fasta hastighetslägen för slipning och polering. För bättre livslängd och ökad flexibilitet kan bandlängden justeras. Som tillval kan maskinen utrustas med utsug.

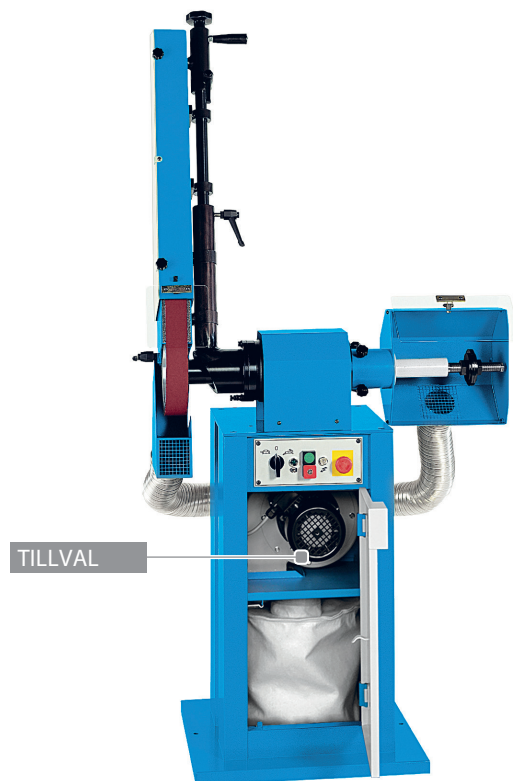

Volt 400 kW 1,8								
hp	Rpm	m/s	dB	E	F	G	G1	kg
2,5	1400 2800	15 30	70	600	1000	1850	910	115
$\emptyset$ mm	A	B	$\emptyset$ mm	NOT INCLUDED		OPTIONAL		
Ø200x50xØ20	2000+2500	50	Ø250xØ25	IA-2		kW 0,55		







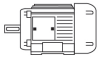

# BEIJERS

## SLIPMASKINER STATIONÄRA

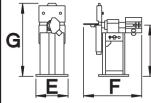
### PELARSLIPMASKIN 34

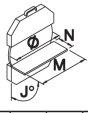



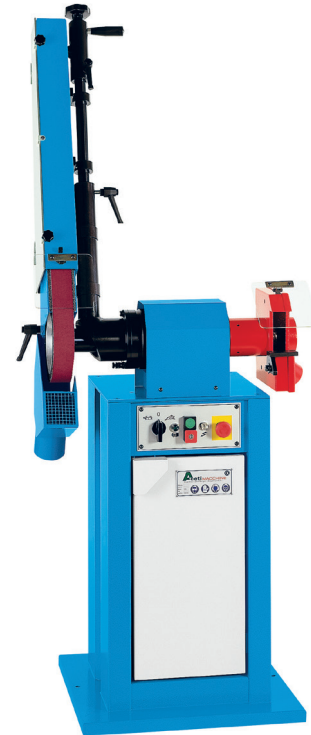

En pelarslipmaskin med två fasta hastighetslägen för slipning. För bättre livslängd och ökad flexibilitet kan bandlängden justeras. Som tillval kan maskinen utrustas med utsug.

								
Volt 400 kW 1,8								
hp	Rpm	m/s	dB	E	F	G	G1	kg
2,5	1400 2800	18 36	70	600	1000	1300	910	120
								
				NOT INCLUDED		OPTIONAL		
Ø	M	N	J°	Ø mm		IA-2		
400	450	230	0°+90°	Ø250xØ25		kW 0,55		

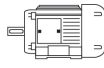

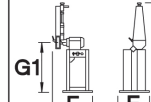
### BANDSLIPMASKIN 28

En bandslip med två fasta hastighetslägen och justerbar bandlängd för bättre livslängd och ökad flexibilitet. Som tillval kan maskinen utrustas med utsug.

								
Volt 400 kW 1,8								
hp	Rpm	m/s	dB	E	F	G	G1	kg
2,5	1400 2800	15 30	70	600	800	1850	910	110
								
				OPTIONAL		IA-1		
Ø mm				A	B	kW 0,55		
Ø200x50xØ20				2000+2500	50			







# BEIJERS

## SLIPMASKINER STATIONÄRA

### BANDSLIPMASKIN 29

En bandslip med två fasta hastighetslägen och justerbar bandlängd för bättre livslängd och ökad flexibilitet. Som tillval kan maskinen utrustas med utsug.

Volt 400 kW 1,8								
hp	Rpm	m/s	dB	E	F	G	G1	kg
2,5	1400 2800	15 30	72	600	850	1850	910	150
Ø mm	A	B	OPTIONAL IA-2					
Ø200x50xØ20	2000÷2500	50	kW 0,55					

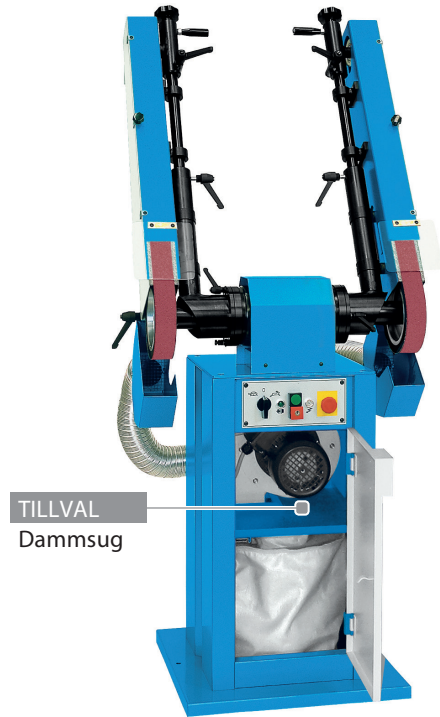

### BANDSLIPMASKIN 68

En pelarslipmaskin med två fasta hastighetslägen för slipning och polering. För bättre livslängd och ökad flexibilitet kan bandlängden justeras. Som tillval kan maskinen utrustas med utsug och inverter för elektronisk justering av hastighet (0-3000 Rpm)

Nr.2 Volt 400 kW 1,8						
hp	Rpm	m/s	E	F	G	G1
2,5	1400 2800	15 30	600	1500	1850	910

dB	kg	A	B	Ø mm	Ø mm	INVERTER ASP.01
70	240	2000÷2500	50	Ø200x50xØ20	Ø250xØ25	Rpm 0÷3000 kW 1,5





# BEIJERS

## SLIPMASKINER STATIONÄRA

### BANDSLIPMASKIN 128

En bandslip med två fasta hastighetslägen och justerbar bandlängd för bättre livslängd och ökad flexibilitet. Som tillval kan maskinen utrustas med utsug och inverter för elektronisk justering av slipbandets hastighet (0-3000 Rpm).



Volt 400 kW 4,4					kg			STANDARD	OPTIONAL	OPTIONAL	OPTIONAL			
hp	Rpm	m/s	E	F	G	G1	dB	kg	A	B	Ø mm	Ø mm	INVERTER	ASP.01
6	1400 2800	18 36	600	820	2200	880	75	185	2500+3000	50	Ø250x50xØ35	Ø250x75-100	Rpm 0+3000	kW 1,5

### BANDSLIPMASKIN 57

En bandslip med två fasta hastighetslägen och justerbar bandlängd för bättre livslängd och ökad flexibilitet. Som tillval kan maskinen utrustas med utsug och inverter för elektronisk justering av slipbandets hastighet (0-3000 Rpm).

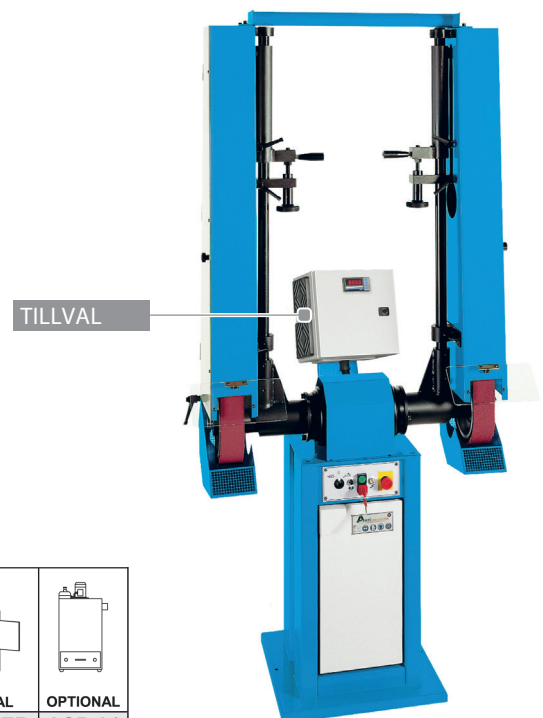

Volt 400 kW 4,4					kg			STANDARD	OPTIONAL	OPTIONAL	OPTIONAL			
hp	Rpm	m/s	E	F	G	G1	dB	kg	A	B	Ø mm	Ø mm	INVERTER	ASP.01
6	1400 2800	18 36	600	1100	2200	880	75	260	2500+3000	50	Ø250x50xØ35	Ø250x75-100	Rpm 0+3000	kW 1,5



# BEIJERS

## SLIPMASKINER STATIONÄRA

### BANDSLIPMASKIN 58

En bandslip med två fasta hastighetslägen och justerbar bandlängd för bättre livslängd och ökad flexibilitet. Som tillval kan maskinen utrustas med utsug och inverter för elektronisk justering av slipbandets hastighet (0-3000 Rpm).



 Nr.2 Volt 400 kW 4,4		 G1 F E G		 dB	 kg	 A B		 STANDARD Ø250x50xØ35	 OPTIONAL Ø250x75-100	 OPTIONAL INVERTER Rpm 0-3000	 OPTIONAL ASP.01 kW 1,5			
hp	Rpm	m/s	E	F	G	G1	dB	kg	A	B	Ø mm	Ø mm	INVERTER	ASP.01
6	1400 2800	18 36	600	1670	2200	880	75	365	2500+3000	50	Ø250x50xØ35	Ø250x75-100	Rpm 0-3000	kW 1,5

### PELARSLIPMASKIN 72

En pelarslipmaskin med två fasta hastighetslägen för slipning och polering. För bättre livslängd och ökad flexibilitet kan bandlängden justeras. Som tillval kan maskinen utrustas med utsug och inverter för elektronisk justering av hastighet (0-3000 Rpm).



 Volt 400 kW 4,4		 G1 F E G		 dB	 kg	 A B		 STANDARD Ø250x50xØ35	 NOT INCLUDED Ø300xØ35	 OPTIONAL INVERTER Rpm 0-3000	 OPTIONAL ASP.01 kW 1,5			
hp	Rpm	m/s	E	F	G	G1	dB	kg	A	B	Ø mm	Ø mm	INVERTER	ASP.01
6	1400 2800	18 36	600	1100	2200	880	70	200	2500+3000	50	Ø250x75-100	Ø300xØ35	Rpm 0-3000	kW 1,5



# BEIJERS

## SLIPMASKINER STATIONÄRA

### PELARSLIPMASKIN 70

En pelarslipmaskin med två fasta hastighetslägen för slipning och polering. För bättre livslängd och ökad flexibilitet kan bandlängden justeras. Som tillval kan maskinen utrustas med utsug och inverter för elektronisk justering av hastighet (0-3000 Rpm).



Nr.2 Volt 400 kW 4,4		G1		E		F		G		G1		dB		kg		A		B		OPTIONAL		Ø mm		INVERTER		OPTIONAL	
hp	Rpm	m/s	E	F	G	G1	dB	kg	A	B	OPTIONAL	Ø mm	INVERTER	OPTIONAL	ASP.01												
6	1400 2800	18 36	600	1650	2200	880	73	295	2500+3000	50	Ø250x75-100	Ø300xØ35	Rpm 0+3000	kW 1,5													

### POLERMASKIN 66/74

En polermaskin med två fasta hastighetslägen. Som tillval kan maskinen utrustas med utsug.

ART. 74

ART. 66

Volt 400 kW 4,4		E		F		G1		L		kg	
hp	Rpm	m/s	dB	E	F	G1	L	kg			
6	1400 2800	22 44	70	600	950	890	370	90			
NOT INCLUDED		OPTIONAL		OPTIONAL		OPTIONAL					
Ø mm		Rpm		INVERTER		IA-1					
Ø300xØ35		700+1400		Rpm 0+3000		kW 0,55					

Volt 400 kW 1,8		E		F		G1		L		kg	
hp	Rpm	m/s	dB	E	F	G1	L	kg			
2,5	1400 2800	18 36	70	600	950	910	350	80			
NOT INCLUDED		OPTIONAL		OPTIONAL		OPTIONAL					
Ø mm		INVERTER		IA-1							
Ø250xØ25		Rpm 0+3000		kW 0,55							







# BEIJERS

## SLIPMASKINER STATIONÄRA

### POLERMASKIN 27/46

En polermaskin med två fasta hastighetslägen. Som tillval kan maskinen utrustas med utsug och inverter för elektronisk justering av hastighet (0-3000 Rpm).



ART. 27

Volt 400 kW 1,8								
hp	Rpm	m/s	dB	E	F	G1	L	kg
2,5	1400 2800	18 36	70	600	1000	910	300	85
NOT INCLUDED	OPTIONAL	OPTIONAL	OPTIONAL					
Ø mm	Rpm	INVERTER	IA-2					
Ø250xØ25	Rpm 0+3000		kW 0,55					

ART. 46

Volt 400 kW 4,4								
hp	Rpm	m/s	dB	E	F	G1	L	kg
6	1400 2800	22 44	70	600	1050	890	320	105
NOT INCLUDED	OPTIONAL	OPTIONAL	OPTIONAL					
Ø mm	Rpm	INVERTER	IA-2					
Ø300xØ35	700+1400	Rpm 0+3000	kW 0,55					

### POLERMASKIN 71

En polermaskin med två fasta hastighetslägen. Som tillval kan maskinen bland annat utrustas med utsug och inverter för elektronisk justering av hastighet (0-3000 Rpm).



Nr.2 Volt 400 kW 4,4												
hp	Rpm	m/s	E	F	G1	L	dB	kg	Ø mm	Rpm	INVERTER	ASP.01
6	1400 2800	22 44	600	1600	890	350	70	250	Ø300xØ35	700+1400	Rpm 0+3000	kW 1,5







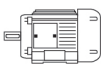
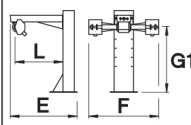

## POLERMASKIN 95

En höj- och sänkbar polermaskin med två fasta hastighetslägen. Som tillval kan maskinen utrustas med utsug och inverter för elektronisk justering av hastighet (0-3000 Rpm).









						
Volt 400 kW 5,5						
hp	Rpm	m/s	E	F	G1	L
7,5	1400 2800	29 58	1450	1050	430-1500	1000

					
	kg	NOT INCLUDED	OPTIONAL	OPTIONAL	OPTIONAL
dB	kg	Ø mm	Rpm	INVERTER	ASP.01
70	425	Ø400xØ35	700-1400	Rpm 0-3000	kW 1,5

## POLERMASKIN 139

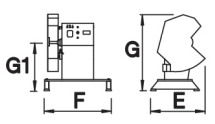
En polermaskin med inverter för elektronisk justering av hastighet (0-3000 Rpm). Som tillval kan maskinen utrustas med utsug.



									
INVERTER					NOT INCLUDED	OPTIONAL			
Nr.1 Volt 400 kW 5,5									
hp	Rpm	E	F	G	G1	dB	kg	Ø mm	ASP.01
7,5	0-1500	1460	1560	1600	1000	75	1050	Ø960 x 100 x Ø45	kW 3









# BEIJERS

## SLIPMASKINER STATIONÄRA

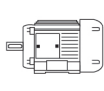
### POLERMASKIN 140

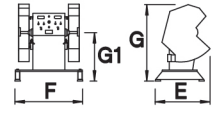
En polermaskin med inverter för elektronisk justering av hastighet (0-3000 Rpm). Som tillval kan maskinen utrustas med utsug.







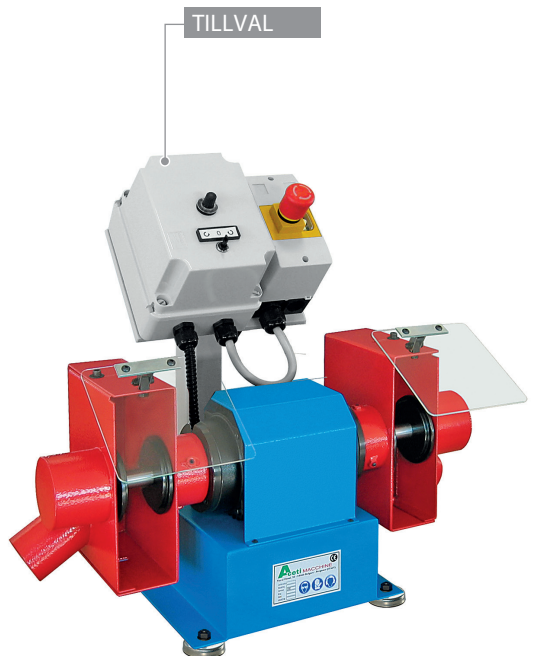

									
Nr.2 Volt 400 kW 5,5				kg	NOT INCLUDED	OPTIONAL			
hp	Rpm	E	F	G	G1	dB	kg	Ø mm	ASP.01
7,5	0 + 1500	1460	1560	1600	1000	75	1150	Ø960 x 100 x Ø45	kW 3

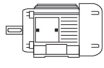
### POLERMASKIN 132

En liten och smidig bänkmaskin som kan utrustas med inverter för elektronisk justering av hastighet (0-3000 Rpm), pelarställ och utsug som tillval.



								
Volt 400 kW 1,1								
hp	Rpm	m/s	dB	E	F	G	G1	kg
1,5	2800	30	69	590	350	300	175	28
				OPTIONALS				
NOT INCLUDED								
Ø mm				Volt 230/1F		kg		
Ø200x50xØ20				INV.MF		BAS.01		
				Rpm 0+3000		ASP.04		



# BEIJERS

## SLIPMASKINER STATIONÄRA

### SLIPMASKIN 133

En liten och smidig bänkmaskin som kan utrustas med inverter för elektronisk justering av hastighet (0-3000 Rpm), pelarställ och utsug som tillval.

Volt 400 kW 1,1								
hp	Rpm	m/s	dB	E	F	G	G1	kg
1,5	2800	30	69	590	440	300	155	28
				OPTIONALS				
NOT INCLUDED								
Ø mm				Volt 230/1F				
Ø200x25xØ20				INV.MF				
				Rpm 0+3000				
				BAS.01				
				ASP.04				



### BÄNKSLIPMASKIN 134

En liten och smidig bänkmaskin för slipning och polering som kan utrustas med inverter för elektronisk justering av hastighet (0-3000 Rpm), pelarställ och utsug som tillval.

Volt 400 kW 1,1								
hp	Rpm	m/s	dB	E	F	G	G1	kg
1,5	2800	30	69	590	440	300	155	28
				OPTIONALS				
NOT INCLUDED								
Ø mm				Volt 230/1F				
Ø200x25xØ20				INV.MF				
				Rpm 0+3000				
				BAS.01				
				ASP.04				







# BEIJERS

## SLIPMASKINER STATIONÄRA

### BORRSLIPMASKIN 101

En borrarlipmaskin med två stycken slipstationer för slipning av borrarpsatsar  
Som tillval kan maskinen utrustas med utsug.



Volt 400 kW 1,8								
hp	Rpm	m/s	dB	E	F	G	G1	kg
2,5	1400 2800	15 30	70	700	1350	1300	1030	130
						OPTIONAL		
Arm A	Arm B	$\alpha^\circ$	$\varnothing$ mm	D-AFF	IA-2			
$\varnothing 5+35$	$\varnothing 35+70$	118°	$\varnothing 200 \times 40 \times \varnothing 20$	Nr. 1	kW 0,55			

### ASP 04

Utsug med centrifugalsystem för uppsamling av slipdamm.



Volt 400 kW 0,55							
hp	Rpm	dB	E	F	G	G1	kg
0,75	2800	70	600	600	780	530	45
Portata max		Pressione totale max					
m <sup>3</sup> /h		mm H <sub>2</sub> O					
1000		85					







# BEIJERS

## SLIPMASKINER STATIONÄRA

### ASP 03

Utsug med centrifugalsystem för uppsamling av slipdamm.





							
Volt 400 kW 0,75							
hp	Rpm	dB	E	F	G	G1	kg
1	2800	70	650	650	1400	1075	55
Portata max m <sup>3</sup> /h			Pressione totale max mm H <sub>2</sub> O				
520			310				





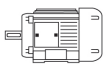

### HP2/HP4

Utsug med cyklonsystem för uppsamling av slipdamm.

#### HP2

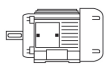
							
Volt 400 kW 1,5							
hp	Rpm	dB	E	F	G	G1	kg
2	2800	72	650	650	1550	1060	133
Portata max m <sup>3</sup> /h			Pressione totale max mm H <sub>2</sub> O				
940			385				

#### HP4

							
Volt 400 kW 3							
hp	Rpm	dB	E	F	G	G1	kg
4	2800	74	750	750	1900	1325	195
Portata max m <sup>3</sup> /h			Pressione totale max mm H <sub>2</sub> O				
1360			485				



**BEIJERS**  
EN DEL AV **BEJERTECH**