

Beijer Industri, affärssegment slipmaterial, arbetar kontinuerligt med kundanpassade lösningar där vi med lång erfarenhet och bred kompetens strävar efter att finna den bästa lösningen för dig som kund. För att lyckas med detta skulle vi vilja be er att besvara frågorna nedan. Har ni frågor är ni välkomna att kontakta oss.

Diameter

D, K, J (mm)

Bredd

T, E, L (mm)

Centrumhål

H (mm)

Form

Profil

V, R

Beläggning

W, X, T, U (mm)

Skruvhål

Antal, Håldiameter

Skruvhål

P (mm), Delning °

Årsförbrukning

St.

Slipmetod

- Fri hand*
 Manuell matning
 Automatisk slipning

Slipmetod

- Grovslipning*
 Planslipning
 Rundslipning

- Profilslipning*
 Verktogs slipning
 Kapning

Typ av verktyg

Verktygets dimensioner

mm

Del av verktyg som ska slipas

Slipmån

mm

Skärdjup

mm

Maskintyp

Benämning

Typ av kylning

- Olja*
 Emulsion
 Torrslipning

Slipskivans hastighet

m/s / rpm

Arbetsstyckets hastighet

m/min / rpm

Ytkrav

μm

- Rz* *Annan*
 Ra
 Rt

Material

Benämning

Härdat/ohärdat

- Härdat*
 Ohärdat

Typ av härdning

Materialets hårdhet

Nuvarande slipskiva

Tillverkare

Slipkorn (typ)

Kornstorlek

Hårdhet

Koncentration

Bindmedel

Bindmedel Spec.

Typ av dresenhet

Skärpskiva Skärpdiamant Bryne Annan

Vad kan vi förbättra?

Beskriv vad vi skulle kunna förbättra (exempelvis avverkningshastighet, yta, livslängd m.m.)

Skickas till

E-post: slip@beijerind.se

Tel: +46 40 35 83 26



Om möjligt, bifoga gärna ritningar på den slipskiva ni använder idag.

1A1

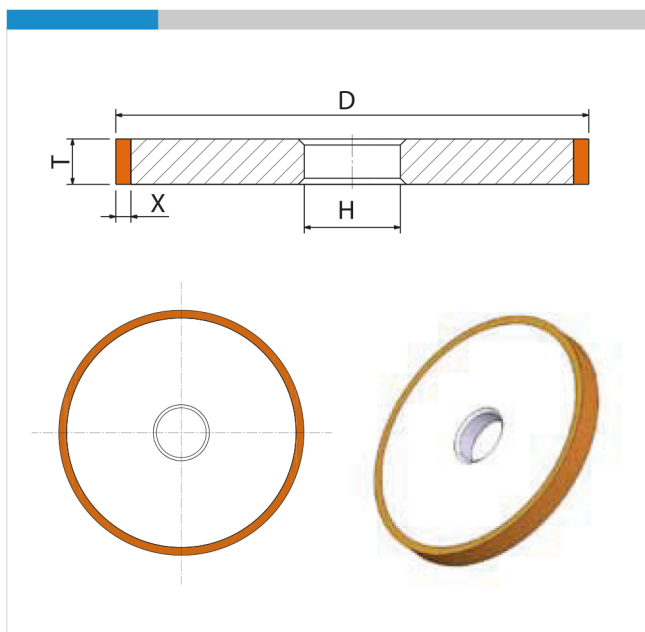

1A1R

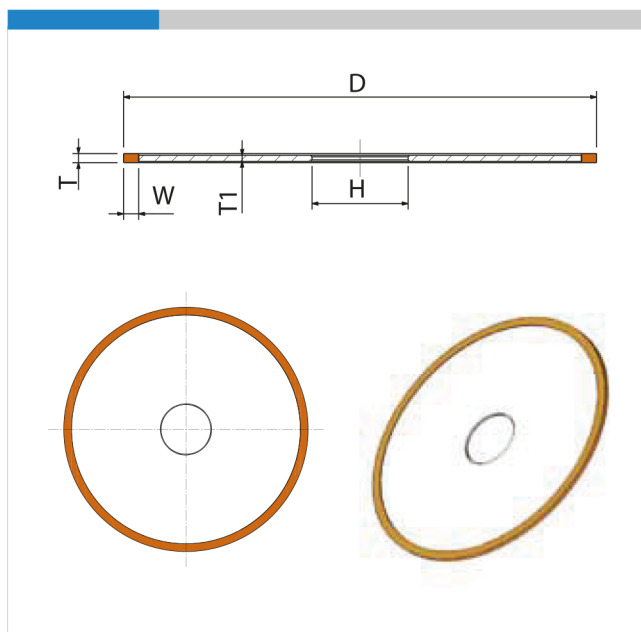

1A8

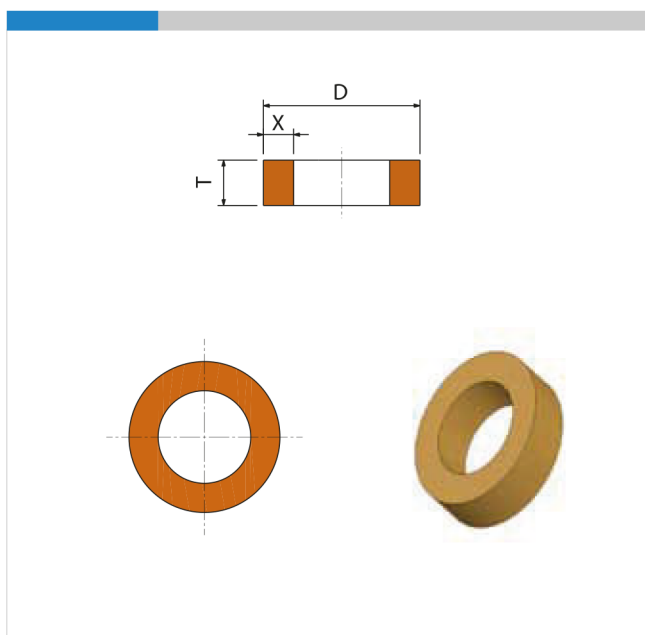

1E1

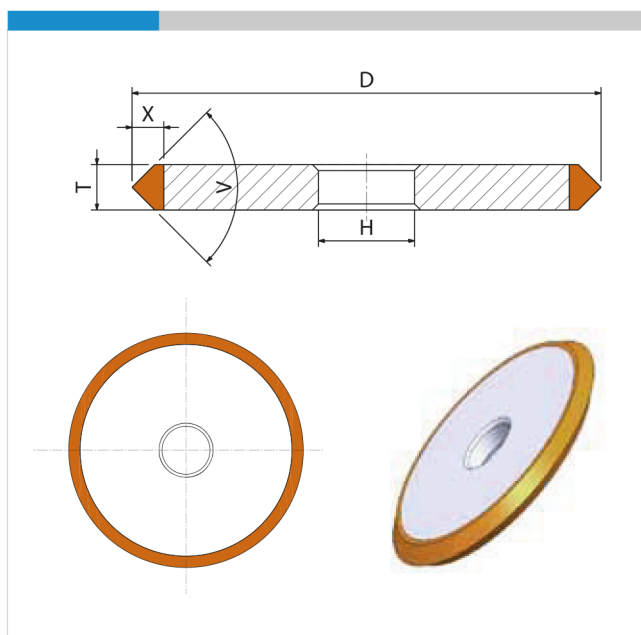

1E6Q

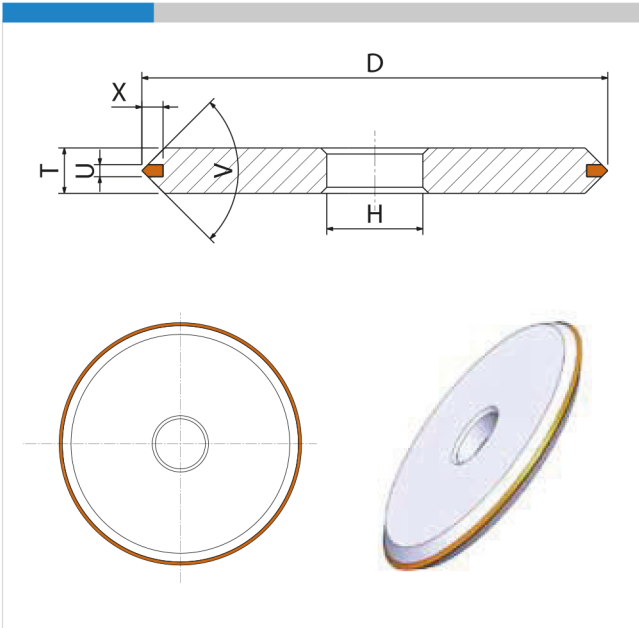

1EE1

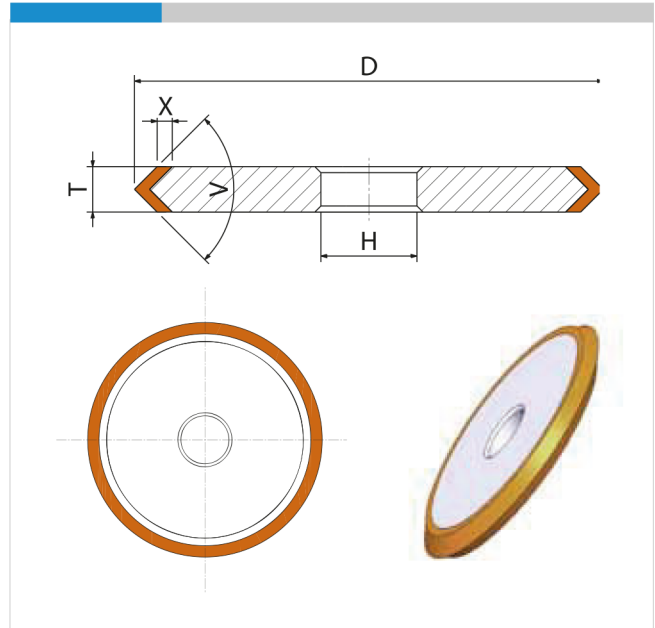

1FF1

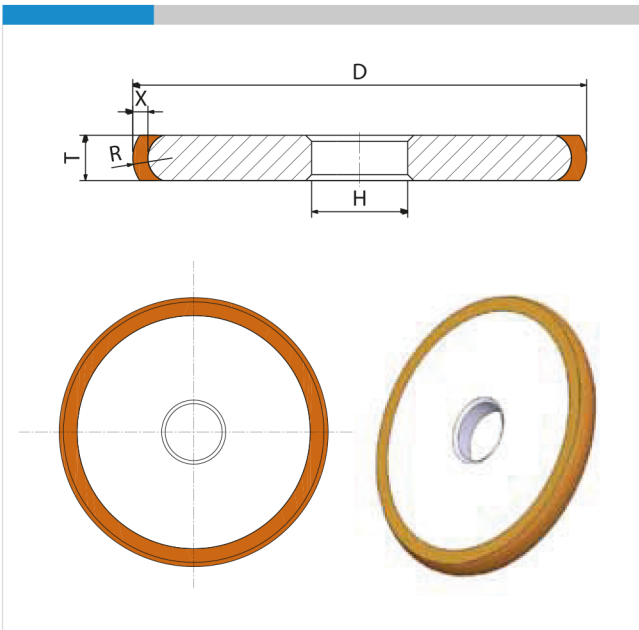

1FF6Y

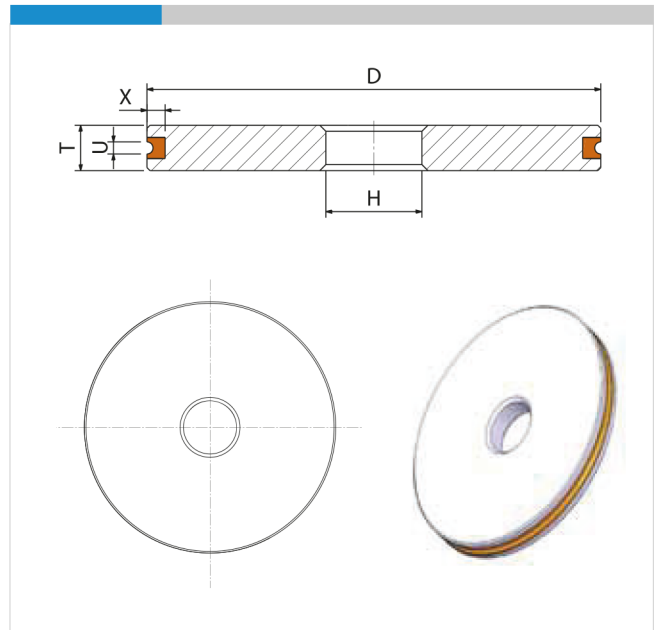



1V1

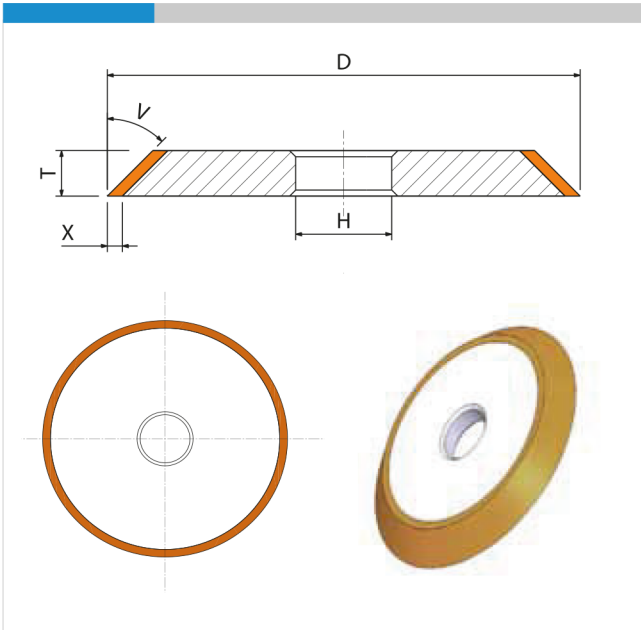

2A2T

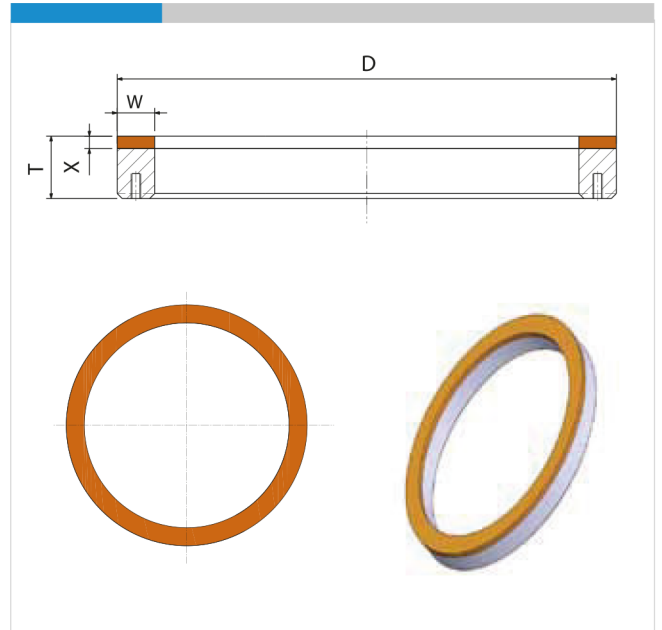

2FF2

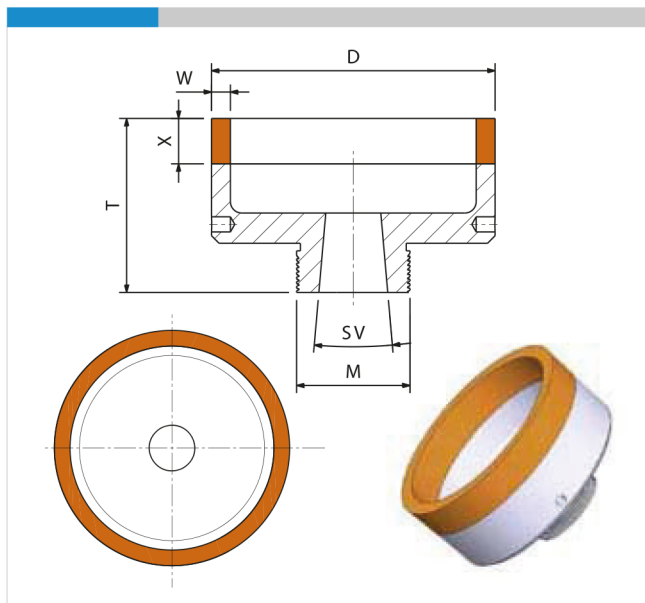

3A1

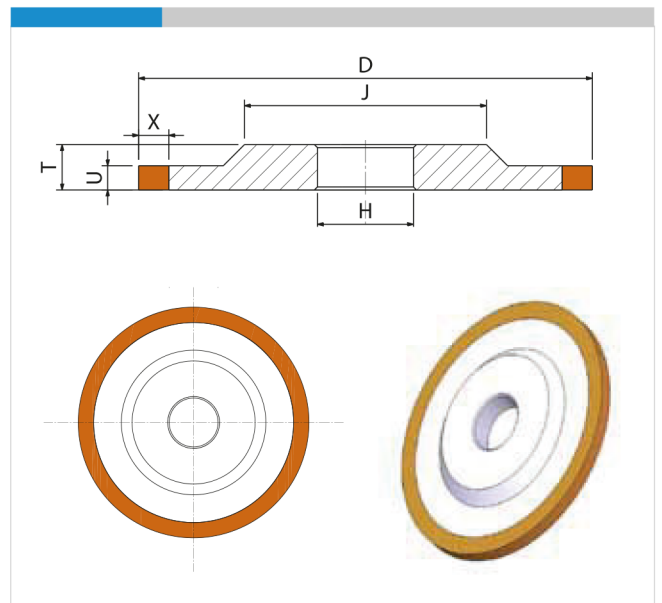



4A2

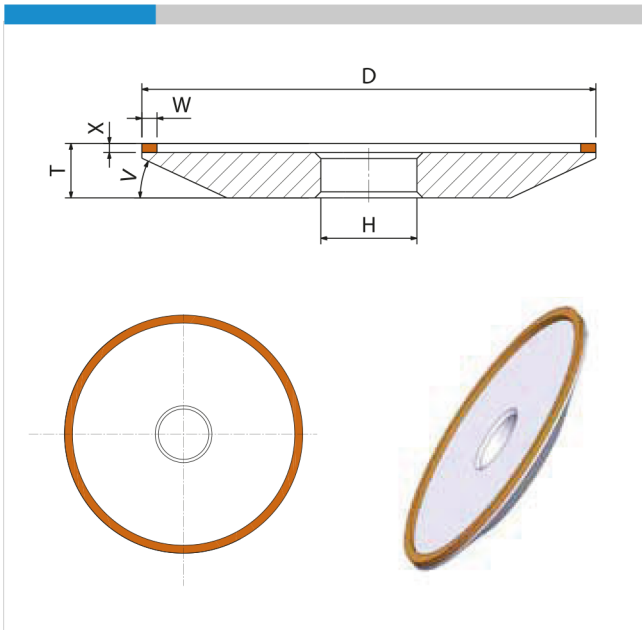

4B2

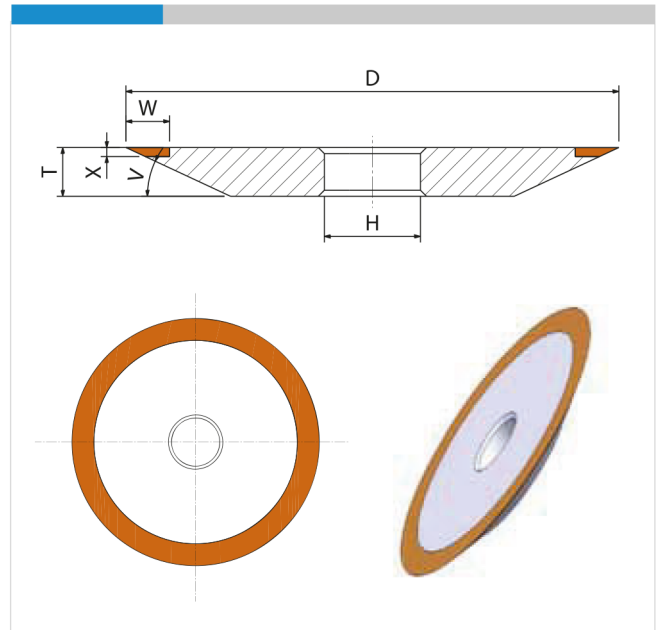

4M1

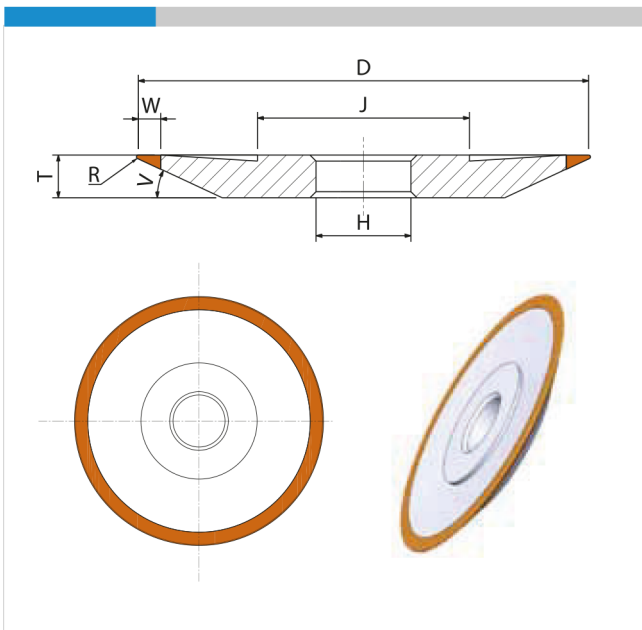

6A2

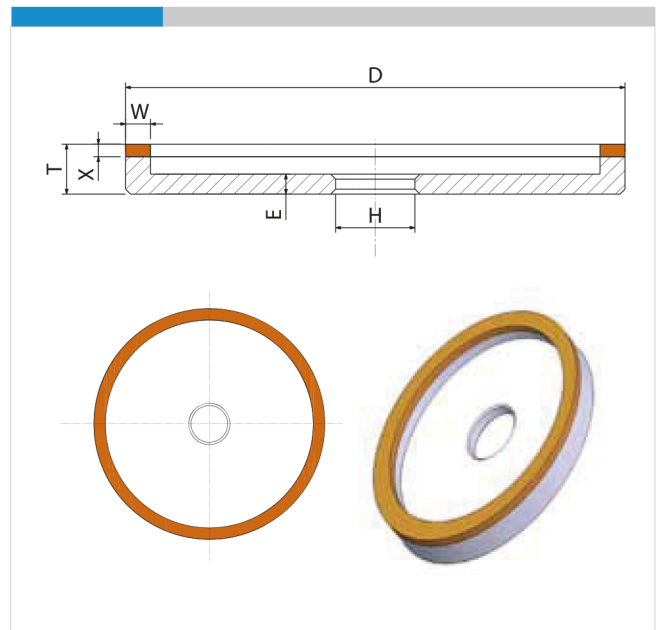



BEIJERS

OFFERTUNDERLAG

6A2C

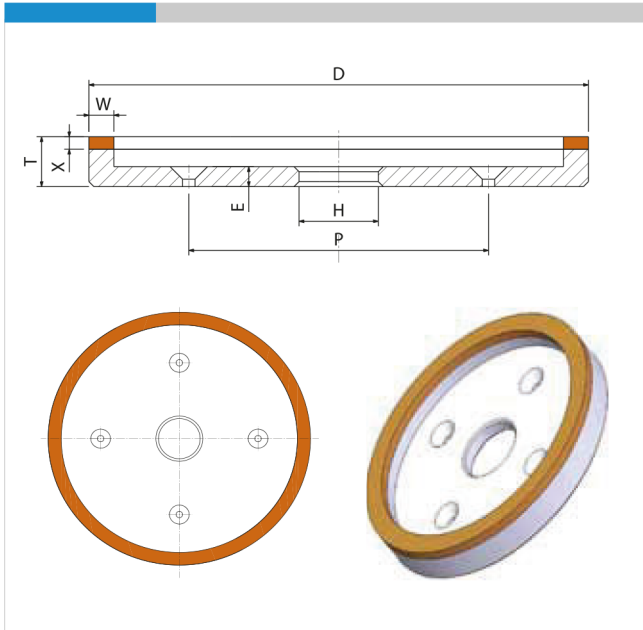

6A9

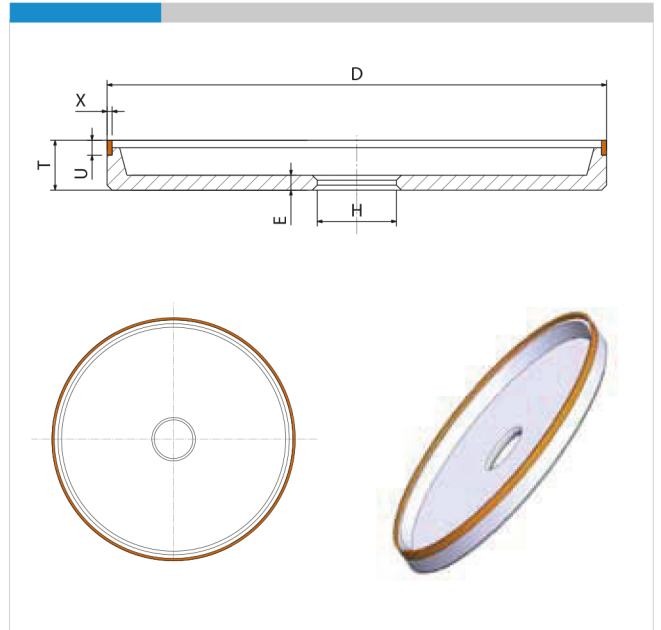

6F2

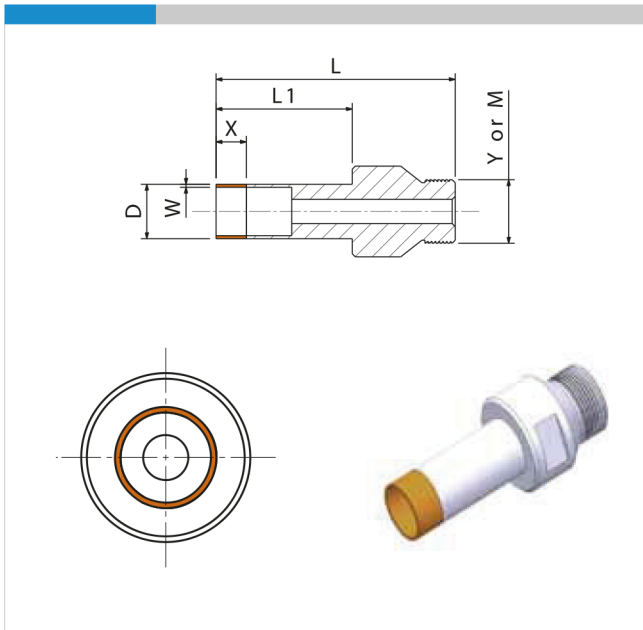

9A3

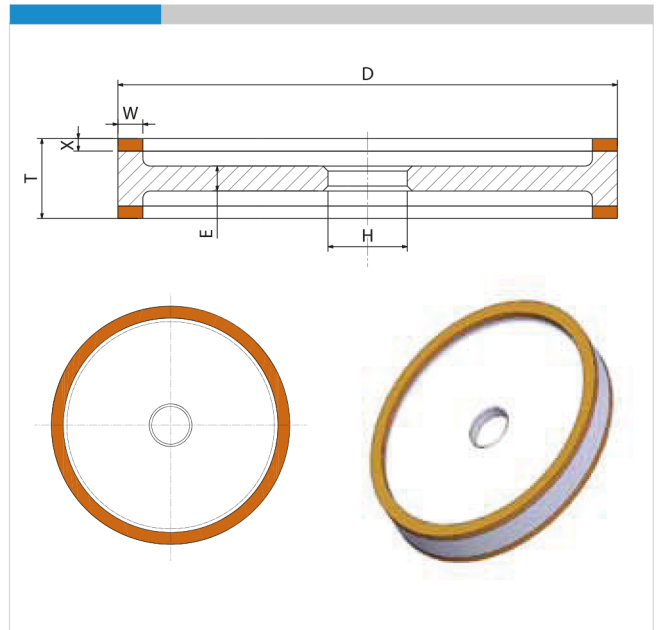



11A2

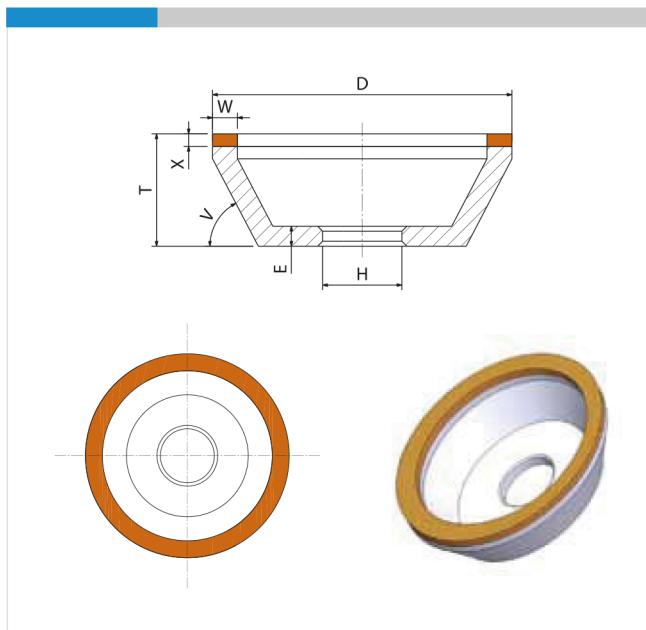

11B2

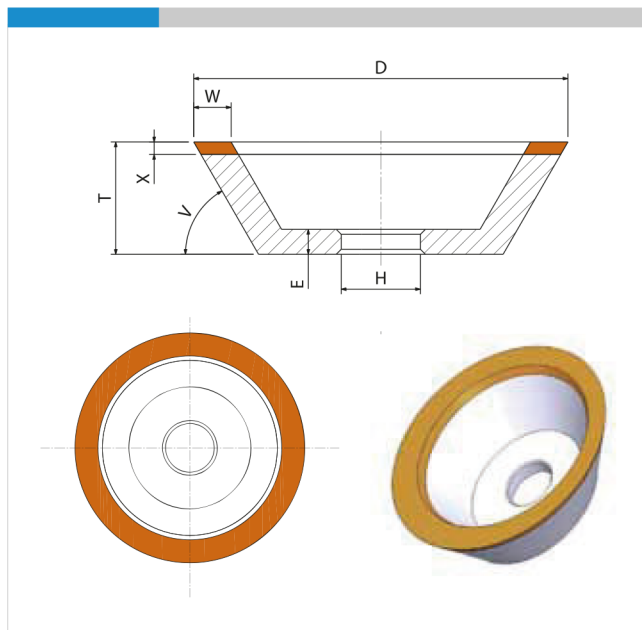

11C9

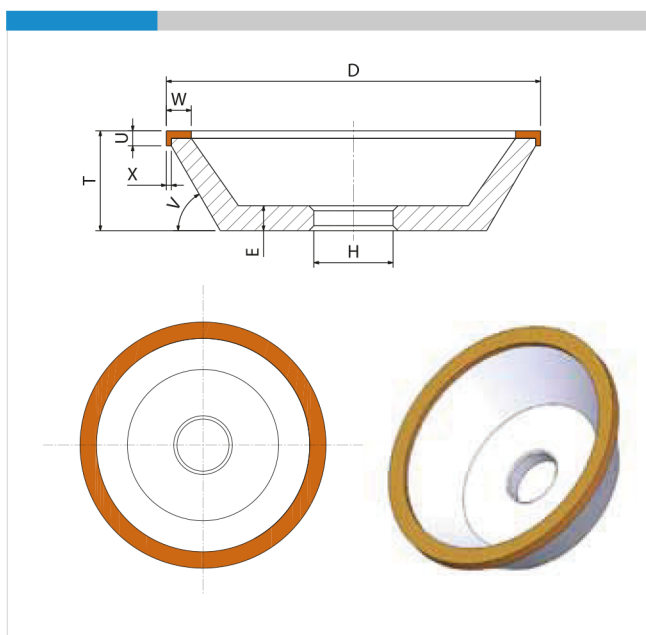

11V9

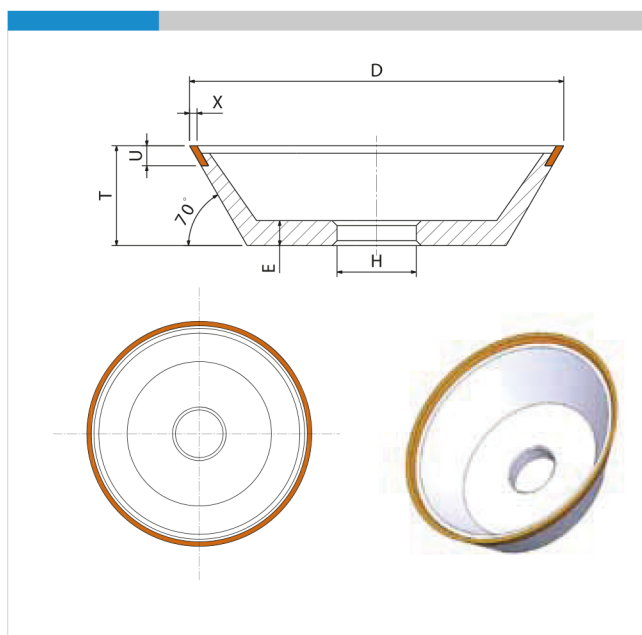



BEIJERS

OFFERTUNDERLAG

11Y9

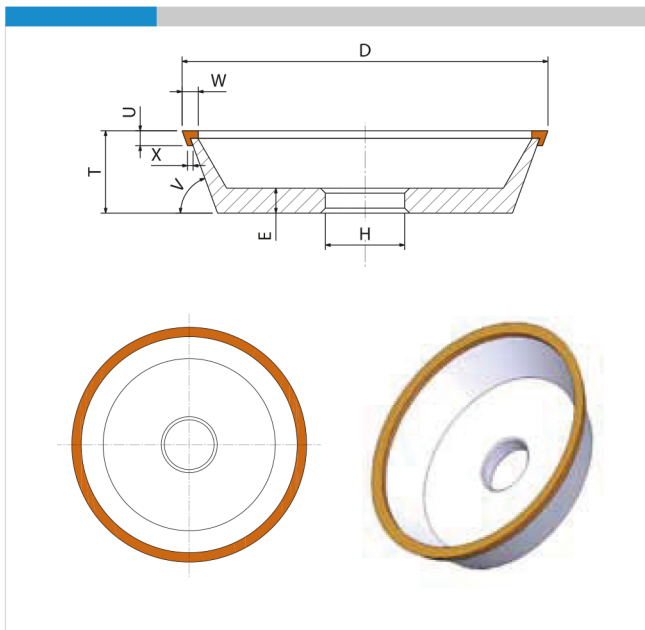

12A2

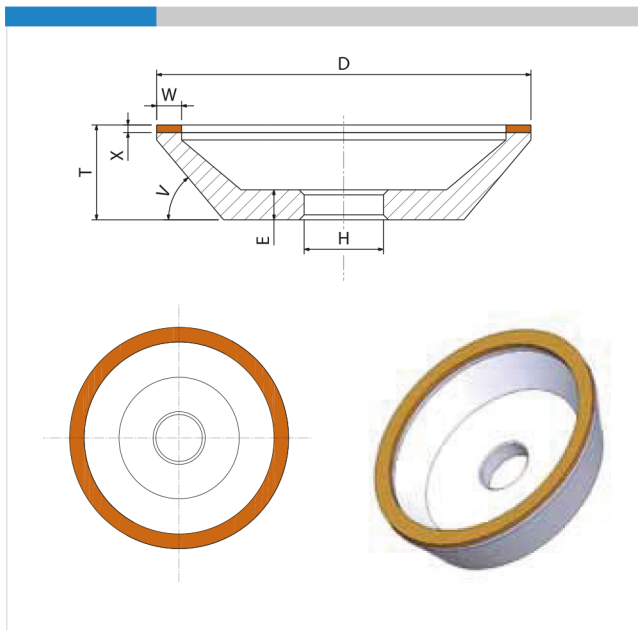

12V4

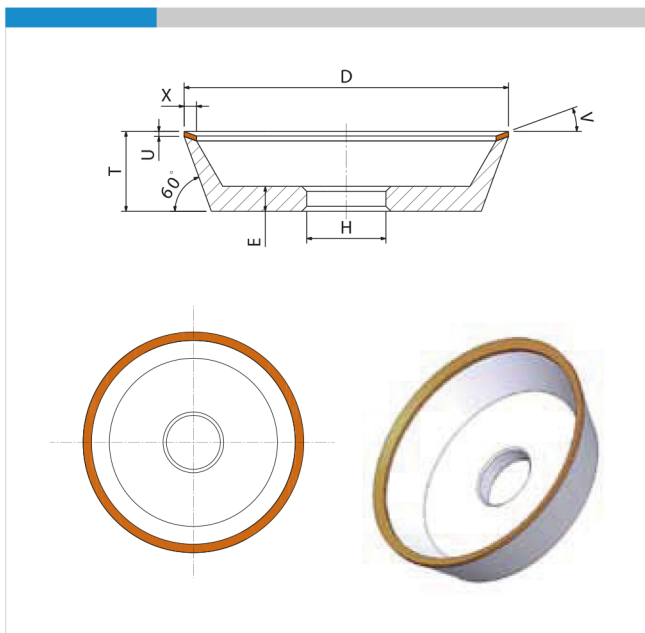

12V9

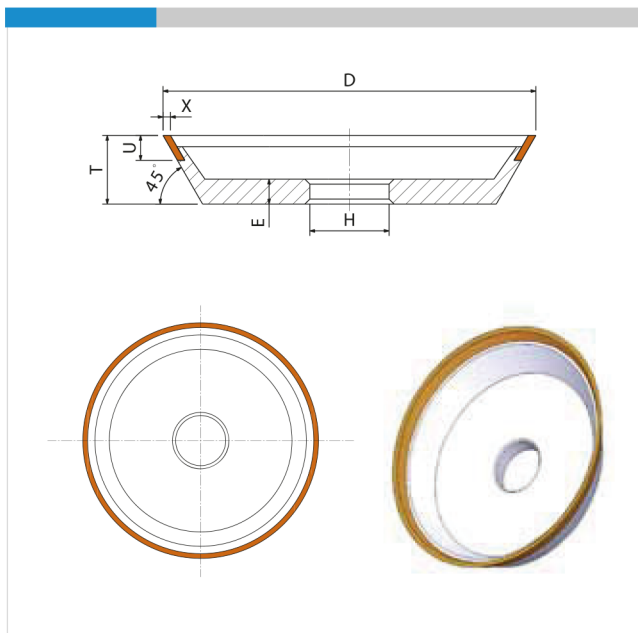



14A1

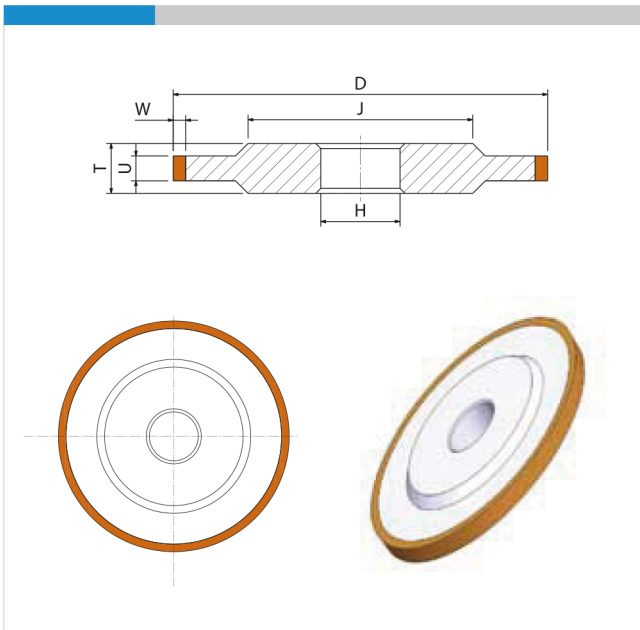

14EE1

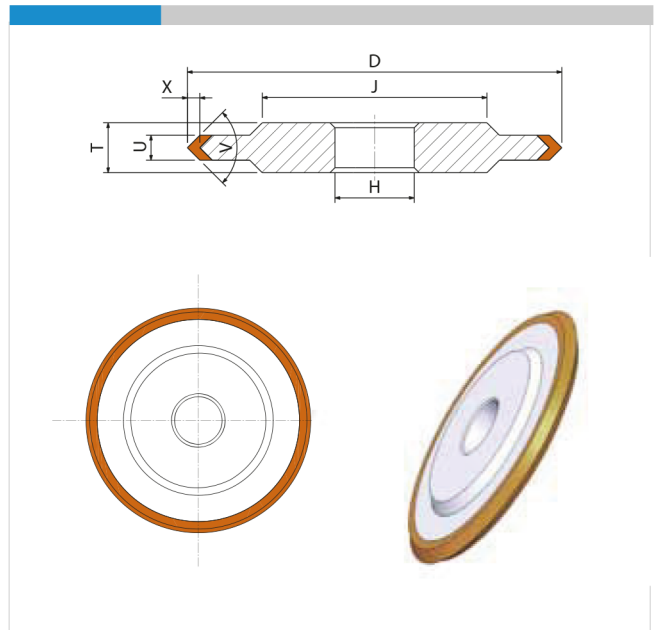

14U1

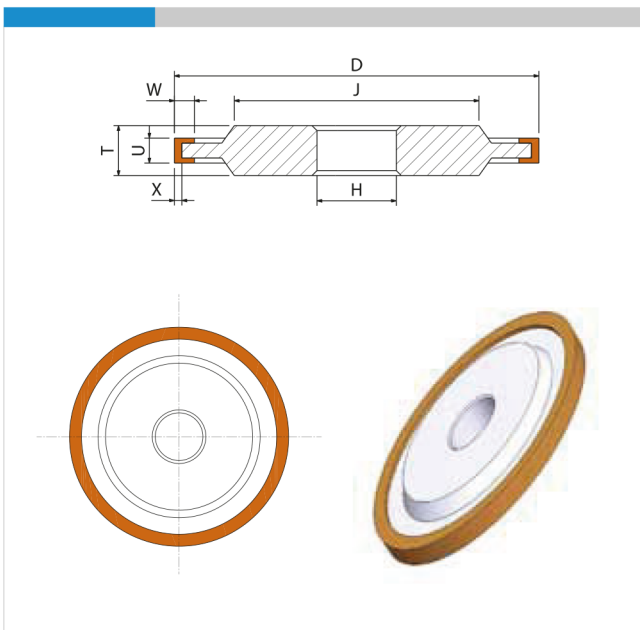

DW

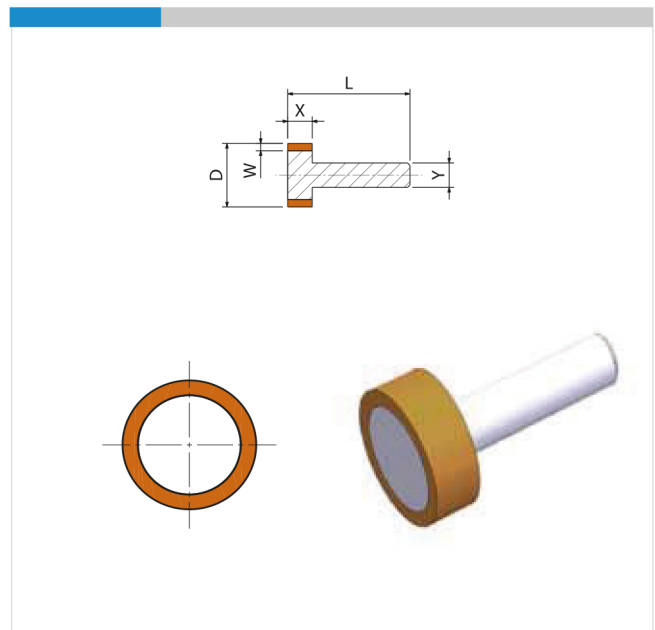



BEIJERS

OFFERTUNDERLAG

BUL

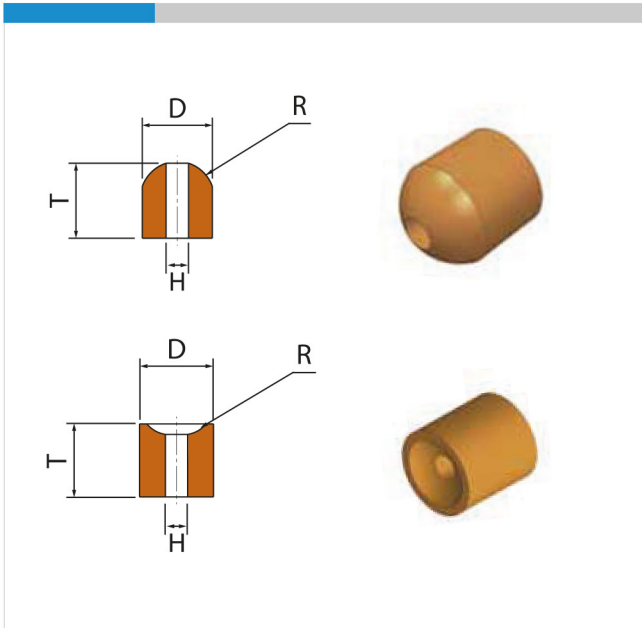

HH1

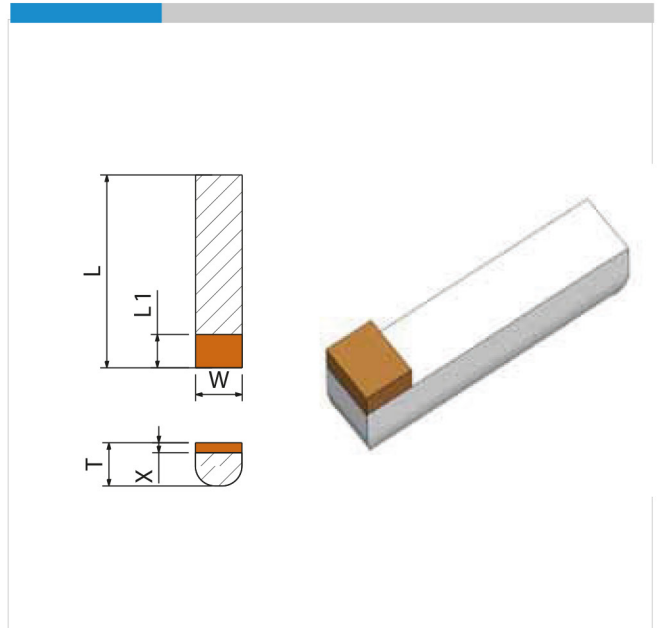

HMF

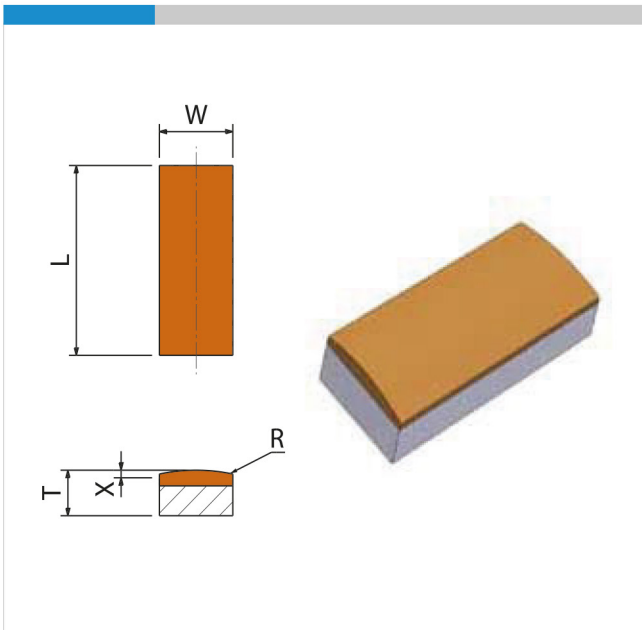

PEL

